



Skyline Roofing®

Installation, Flashings and Details Guide

Table of Contents

Section	Page	Section	Page
Introduction	2	Endwall Flashing	29
Delivery, Handling and Storage	3	Vented Endwall Flashing	30
Safety Considerations	3	Slope Transition - High to Low Slope	31
Equipment	4	Slope Transition - Low to High Slope	32
Skyline Roofing® Panel Profile	4	Outside Corner Flashing	33
Minimum Recommended Tools & Roof Preparation	5-6	Inside Corner Flashing	34
Map of Typical Roof Conditions	7	Base Trim at Drip/Head Flashing	35
Fastener Selection	8	“C” Trim Flashing/Soffit	36
Panel Installation	9-10	Chalet Gable Flashing	37
Hip/Ridge Flashing	11	Adjustable Gable Flashing	38
Vented Ridge Flashing	12	Knee Cap Flashing	39
Vented Ridge Termination	13	Vent Flashing	40
Valley Flashing	14	Skylight Flashing	41
Valley Termination	15	Skylight Flashing (Side)	41
Eave and Vented Eave Flashings	16	Skylight Flashing (Uphill)	42
Eave Flashing Preparation	17	Skylight Flashing (Downhill)	43
Gutter and Gutter With Vented Eave	18	Procedure for the Installation of Skylight Flashings	44
Start Gable Flashing	19	Skylight Flashing Preparation	44-45
End Gable Flashing	20	Chimney Flashing	46
Gable/Ridge Transition	21	Chimney Flashing (Side)	47
Gable Corner at Eave	21	Chimney Flashing (Uphill)	48
Gable Flashing Preparation	22	Chimney Flashing (Downhill)	48
Gable Flashing Preparation at Ridge	23	Typical Flashing Lap	49
Peak Flashing	24	Valley Top End	50
Vented Peak Flashing	25	Valley Dormer	51
Sidewall Flashing (panels under 40 ft.)	26		
Sidewall Flashing (panels over 40 ft.)	27		
Closing Sidewall Flashing	28		

**For additional installation visuals, please check out the Skyline Roofing
Installation Video on our website at: www.ascbp.com/product/skyline-roofing/**

INTRODUCTION

In addition to weather tightness, long life and good looks, ASC Building Products' Skyline Roofing is designed with ease of installation as a primary consideration. This guide is intended to help the installer achieve a high level of quality in the finished product. For additional visuals, please refer to our Skyline Roofing Installation Video available online at www.ascbp.com.

Please do not hesitate to contact an ASC Building Products representative for assistance.

Manufacturing Locations:

Anchorage, Alaska

2441 Cinnabar Loop
Anchorage, AK 99507

West Sacramento, California

2110 Enterprise Boulevard
West Sacramento, CA 95691

Salem, Oregon

4063 Salem Industrial Drive NE
Salem, OR 97303
Customer Service Center
800-272-7023 • 503-390-7174

Spokane, Washington

4111 East Ferry
Spokane, Washington 99202
Customer Service Center
800-776-8771 • 509-536-4097



IBC/IRC Building Code Compliance Report:
Evaluation Report #ER-0309

IMPORTANT NOTICE

Be sure to read this manual in its entirety before beginning installation.

This manual is provided to the customers of ASC Building Products as a guide to assist in the installation of Skyline Roofing. Use for any other purpose is prohibited. This manual remains the property of ASC Building Products.

These instructions contain suggested application procedures only and cannot replace the need for good common sense and experience. Responsibility for conformance to state and local building codes, as well as any other applicable project requirements rests with the installer, as does the responsibility to observe reasonable safety procedures.

Certain panel and flashing conditions such as panel overhangs, gutters, rake trim, etc., are easily damaged if a ladder is leaned against them. Care should be taken to avoid this.

ASC Building Products assumes no responsibility for any problems which might arise as a result of improper installation or any personal injury or property damage that may occur with the product's use.

Notes:

- It is recommended that Skyline Roofing be applied on roofs with a minimum slope of 3 inches per foot (3:12).
- Panels exceeding 40' in length must be fastened using the Skyline Roofing clip (See page 10). Thru-fastening these longer length Skyline Roofing panels is not recommended. For applications requiring the Skyline Roofing clip and exceed 20 psf of snow load, please contact an ASC Building Products Representative for installation details.
- Each flashing part in this guide has been assigned a part number. Each part number contains one or two letters followed by one or two numbers, for example (EW17). These part numbers have been provided for you to make ordering these flashing parts quick and easy.
- To prevent mis-alignment of fasteners and "walking" drill bits, it may be advisable to pre-drill certain flashings before they are installed.

DELIVERY, HANDLING AND STORAGE

- Always check the shipment upon delivery. Check for damage and check material quantities against the shipping list. Note any damaged material or shortages at the time of delivery.
- Handle panel bundles and individual panels with care to avoid damage. Longer bundles and panels may require two or more “pick points,” spaced no farther than 10’ apart, to avoid damage that can result from buckling and/or bending of the panels. Request a copy of the Long Length Handling Instructions and diagrams from ASC Building Products Customer Service as required.
- Store the panels and other materials in a dry, well ventilated area and away from traffic. Elevate one end of the bundle so that any moisture that may have accumulated during shipping can run off. Be sure that air will be able to circulate freely around the bundles to avoid the build-up of moisture. Never store materials in direct contact with the ground.

Note: Excessive storage periods or poor storage conditions often result in water intrusion. Prolonged exposure to wet conditions can cause paint blistering and galvanized substrate corrosion or staining in as little as 2 weeks.

- Painted panels are shipped with a protective plastic sheeting or a strippable film coating between all panels. Remove any strippable film coating prior to installation and in any case, do not allow the strippable film coating to remain on the panels in extreme heat, cold, or in direct sunlight or other UV source.
- Wear clean cotton gloves when handling unpainted bare panels or flashing to avoid discoloration. Rollforming die marks (which appear black), particularly at bends, will be visible.
- Wear clean, non-marking, soft soled shoes when walking on the panels to avoid shoe marks or damage to the finish. Do not step on the panel seams or ribs. Step only in the flat area of the panel.

SAFETY CONSIDERATIONS

- **Never use unsecured or partially installed panels as a working platform.**

Do not walk on panels until they are in place on the roof and all of the fasteners attaching the panels to the roof have been installed.

- **Metal roofing panels are slippery when wet, dusty, frosty or oily.**

Do not walk on a metal roof when any of these conditions are present. Wearing soft soled shoes will help minimize slipping and help prevent damage to the painted surfaces.

- **Do not walk on the panel seams.**

When walking on the fully installed roof panels, be sure to step only in the flat areas of the panels.

- **Always be aware of your position on the roof relative to your surroundings.**

Take note of the locations of roof openings, roof edges, equipment, co-workers, etc.

- **Always wear proper clothing and safety attire.**

Wear proper clothing when working with sheet metal in order to minimize the potential for cuts, abrasions, and other injuries. ASC Building Products recommends safety glasses and gloves.

- **Use care when operating electrical and other power equipment.**

Observe all manufacturer’s safety recommendations.

- **Roof installation on windy days can be dangerous.**

Avoid working with sheet metal products on windy days.

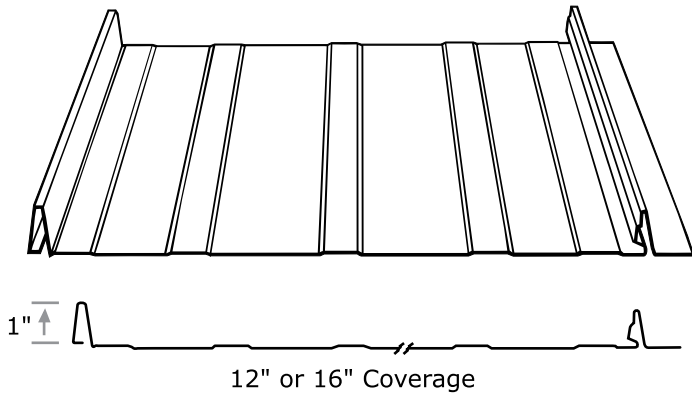

SKYLINE ROOFING PANEL PROFILE

Use only those accessories specifically designed for use with this product. Use only galvanized or ZINCALUME®-coated flashings. Isolate roofing and flashings from contact with dissimilar metals.

Note: All flat metal surfaces can display waviness commonly referred to as "oil canning". This is caused by steel mill tolerances, variations in the steel substrate and roofing underlayments. Oil canning is an inherent characteristic of flat steel products, not a defect, and therefore is not a cause for panel rejection.

Important Note:
 At completion of each day's work and at completion of roof installation, sweep panels, flashings, and gutters clean. Take special care not to sweep metal shavings down into the gutters. Do not allow fasteners, cuttings, filings, or scraps to accumulate.

Available Products:

Coverage	Gauge	Weight (lb/ft ²)
16"	26	0.90
16"	24	1.19
12"	26	0.97

MINIMUM RECOMMENDED TOOLS & EQUIPMENT

Screws/Screw bits: Clutch type screw gun with depth locating nose piece allowing variable torque settings is recommended to insure proper installation of the screws. The following bits will be required: 1/4" hex and No. 2 Phillips screwdriver bit.

Snips: For miscellaneous panel and flashing cutting requirements. Three pairs will be required for left edge, right edge, and centerline cuts.

Electrical Metal Shears: Used for general metal cutting, such as at the hips and valleys.

Note: Some erectors prefer to use circular power saws with metal cutting abrasive blades. While the use of power saws may be faster, there are some disadvantages that must be considered: (1) The edges of metal that have been saw cut are jagged and unsightly, and are more likely to rust than sheared edges. (2) Saw cutting will leave small particles of metal on the panel surface that will rust and damage the panel finish if not completely removed.

Caulking Gun: For miscellaneous caulking and sealing to inhibit water infiltration.

Rivet Tool: Used for miscellaneous flashing and trim applications.

Turn-Up Tool: Available from ASC Building Products, the tool is used to hand brake the ends of the panels as indicated in the details of this manual.

Marking Tools: Indelible marker or scratching tools.

Scratch Awl: Used to mark the steel.

Utility Knife: Used for miscellaneous cutting.

Electric Drill: Used to drill holes such as those required for rivet installation.

String Line: Used for general alignment and measuring.

Tape Measure: 25 ft. minimum (another 50 ft. handy).

Locking Pliers: Standard in "Duckbill" style for miscellaneous clamping and bending of parts.

Hammer: Used with roofing nails to fasten flashings.

Chalk Line: Used to assist in the alignment of panels, flashings, etc.

ROOF PREPARATION

ASC Building Product's Skyline Roofing can be used in both new construction and retrofit roofing applications. Skyline Roofing must be installed over a continuous rigid substrate such as plywood, or OSB. All substrates must be complete, accurately sized and located, in true plane, secure and otherwise properly prepared. Contact ASC Building Products for additional information.

The following steps need to be taken to prepare the roof for installation of Skyline Roofing panels:

New Roofs:

1. Make sure there are no nails or other objects protruding from the substrate that might puncture the underlayment or the roof panels. Clean all debris from the roof.
2. Check all details for possible roof penetrations which must be added to the deck prior to roof panel installation.
3. Cover the entire roof deck with minimum 30 lb. asphalt saturated felt paper. Some synthetic underlayments may be used in place of felt with ASC Building Products' Skyline Roofing. Installer must ensure they meet the minimum standards of 30 lb felt and that the underlayment manufacturer has approved them for use with metal roofing. (Check with an ASC Building Products representative if project is in snow country). For Class A fire resistance, see notes below. For installation begin at the eave and roll the felt horizontally (parallel to the eave). Allow each consecutive course to overlap the previous one 3". Overlap the ends a minimum of 6" when starting a new roll of felt. (See *illustration #1*). Areas of underlayment that have torn should be replaced or repaired prior to installation of the metal roof.

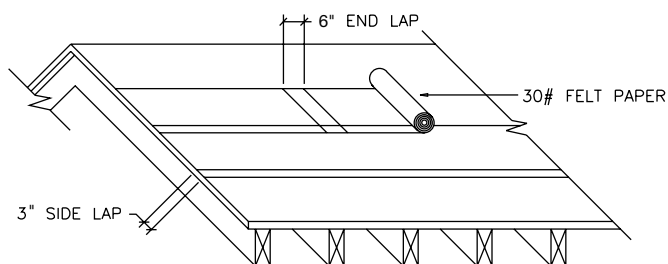

Illustration No. 1

Constructions Requiring Class 'A' Fire Resistance:

Panel: ASC Building Products' Skyline Roofing steel roof panels.

Barrier Sheet (one of the following):

- GAF VersaShield® Underlayment
- Firestone GLAD-GARD™ SA-FR
- Polyglass Polystick® XFR
- Georgia-Pacific DensDeck® Roofboard

Additional Ply Sheet (optional): Any UL-classified Type G1, G2 or G3 base/ply sheet, Type 15, 20 or 30 felt or UL-classified prepared roofing accessory or ASC Building Products' "AEP Span Underlayment HT"

Substrate: 15/32" min. plywood or 7/16" min. OSB.

Notes:

- Obey all local code requirements. Some jurisdictions have special requirements for roofs in high fire risk areas.

- Class A assembly requirements noted above per UL listing #TGFU.R21182. Refer to UL listing for specific construction limitations.

4. Place an alignment line along the gable end where the first roof panel will be installed. THIS LINE MUST BE LOCATED 1/4" IN FROM THE GABLE EDGE OF THE ROOF DECK AND SQUARE WITH THE EAVE LINE. Various methods exist for insuring that the line is square. Call your ASC Building Products representative if you need assistance. (See *illustration #2*).

Note: Check with the underlayment supplier for specific installation and handling instructions. Over exposure to the elements may cause buckling of the felt resulting in an objectionable appearance of the installed roof.

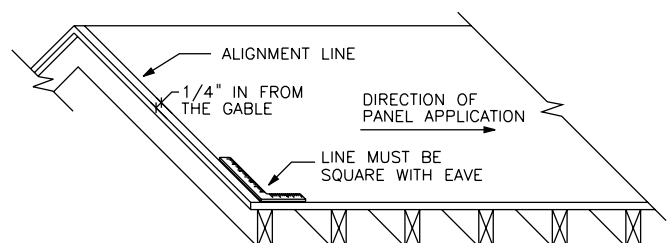

Illustration No. 2

EXISTING ROOFING:

Some jurisdictions will allow reroofing over existing roofing without the need for tearoff. Check with your local codes or building department for your specific requirements.

For best results, Skyline Roofing requires a relatively smooth and flat substrate. Application over rough and/or uneven surfaces is not recommended.

If the roof is to be stripped down to the existing decking, follow the procedures for new roofs on page 5. Be sure to check the existing roof and repair any damaged areas prior to installation of the new roof system.

Note: Do not apply Skyline Roofing over roofs with structural damage or trapped moisture.

The following steps should be taken when installing ASC Building Products' Skyline Roofing over existing roofing:

1. Inspect the roof for damage and make the necessary repairs to achieve a flat plane for the metal roof panels.
2. Secure any warped or loose roofing.
3. Make sure that there are no nails or other objects protruding from the roof that might puncture the new underlayment or the new roof panels.
4. Remove all moss and other debris from the roof.
5. Cut off any overhanging roofing flush with the roof deck and remove all hips, ridge caps, and penetration flashings.
6. Follow the directions on page 5, #2 through #4 on roof preparation.



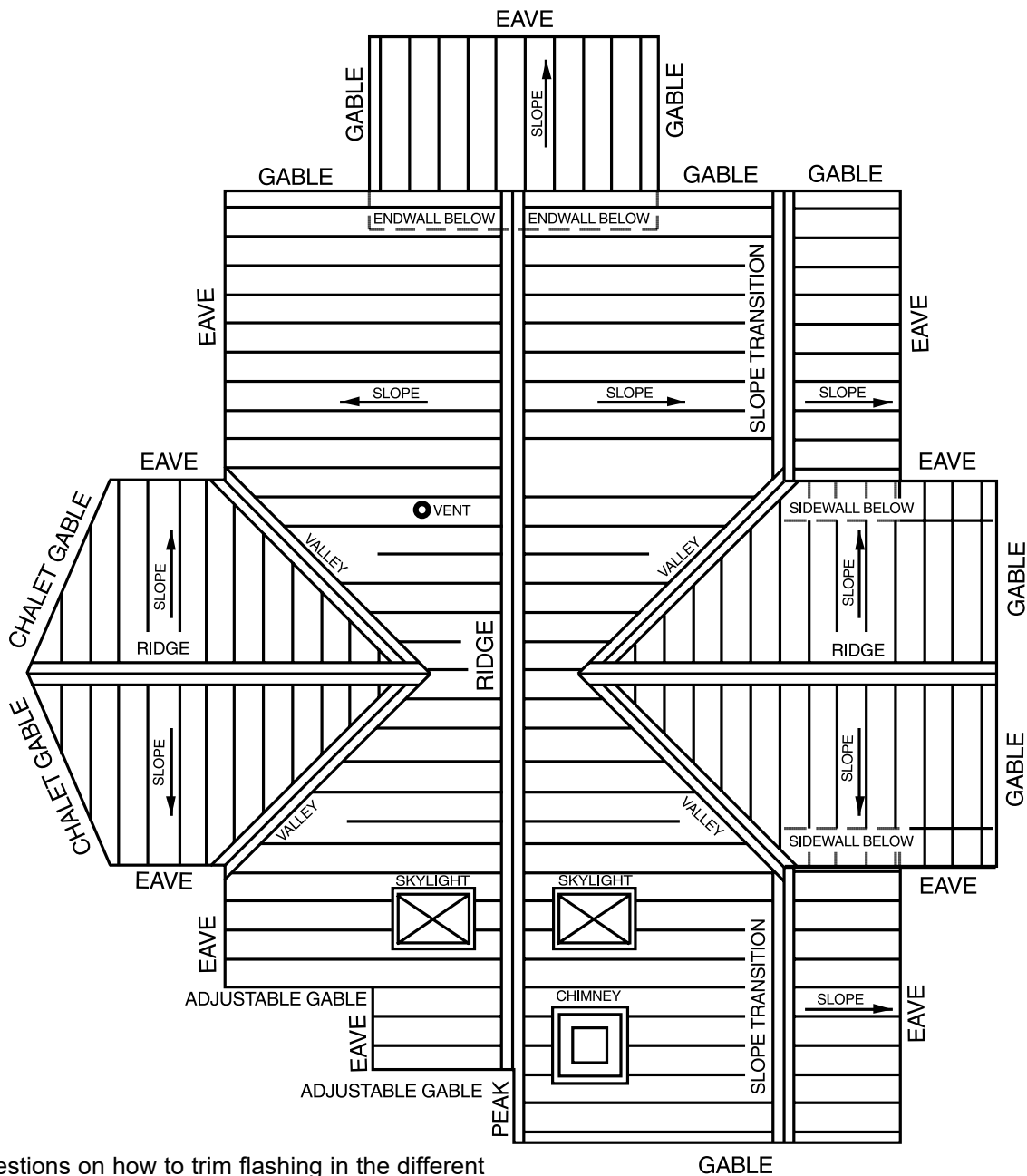







Map of Typical Roof Conditions



For suggestions on how to trim flashing in the different areas, please refer to the following pages:

Flashing	Page(s)	Flashing	Page(s)	Flashing	Page(s)
Adjustable Gable	38	Gable	19-23	Sidewall	26-28
Chalet Gable	37	Gutter	18	Skylight	41-45
Chimney	46-48	Peak	25	Valley	14-15, 50-51
Eave	16-17	Slope Transition	31-32	Vent	40
Endwall	29-30	Ridge & Hip	11-13		

Fastener Selection

Fastener #	Description	Use
	 No. 8 x 1" Modified Truss Head Wood Screw	Panel to wood deck or trim to wood attachments (unexposed).
	 No. 12 x 3/4" Stitch Screw	Panel to panel or trim to panel attachments. May be used as an alternative to blind rivets.
	 No. 14 x 1", 1-1/2" Metal-to-Wood Screw	Panel to wood deck at valleys, eave start panel at gable attachments, and endlaps (exposed)
	 Stainless Steel Rivet 1/8" x 1/8"	Trim to trim attachments (lapped joints).
	 No. 10-12 x 1" Pancake Head Wood Screw	Use when fastening panel to wood deck for increased wind uplift resistance (unexposed).

Notes:

- The table above shows the fasteners required for Skyline Roofing. Refer to the panel installation and flashing details of this manual for specific screw usage and spacing.
- Panel attachment screws must be long enough to fully penetrate through the wood roof decking at least 3/8", or penetrate into solid lumber at least one inch.
- All screws must be coated to provide protection against corrosion.
- Exposed fasteners must have sealing washers and should be the same color as the parts they attach.
- Roofing nails are also required, but are not furnished by ASC Building Products.
- Screws must be properly driven to ensure proper seal and holding strength. Do not underdrive or overdrive the screws.
- Stainless steel rivets are not watertight.

Proper Installation of Gasketed Fasteners

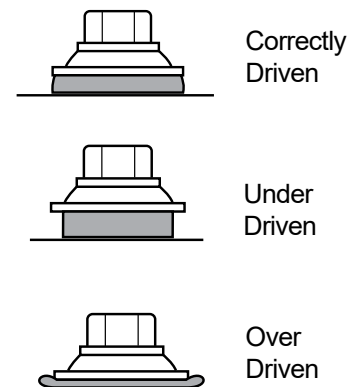

Panel Installation

GENERAL

Study the details section of this manual prior to the installation of the panels. Pay close attention to the following:

- Flashings that need to be installed prior to the panels include Valley, Eave, Vented Eave, Standard Gutter, Vented Gutter, Chalet Gable and Adjustable Gable, and penetration flashings for skylights, chimneys, etc.

- Some panels may require “turn-up” at the uphill end prior to their installation.
- Apply caulking to the pre-installed flashings per the instructions in the detail section of this manual.

Table 1: Panel Attachment & Outward (Wind Uplift) Load Capacities

Panel Width	Panel Gage	Plywood / OSB Thickness Min. ¹	Fastener Size	Fastener Spacing ²	Basic Wind Speed Met (mph) ³ (IRC only)	Outward Wind Load Capacity (psf) ⁴ (IRC and IBC)
16"	26	15/32"	#8 or #10	22"	110	29
	26	15/32"	#8 or #10	11"	110	31
16"	24	15/32"	#8	22"	110	29
	24	15/32"	#10	22"	115	34
	24	15/32"	#8 or #10	11"	130	45
12"	26	15/32"	#8 or #10	22"	115	34
	26	15/32"	#8 or #10	11"	120	39

Notes:

- Alternate substrate thicknesses have not been included as they do not provide greater outward wind load capacities. Inward gravity loads (snow, etc.) are also resisted by the substrate therefore substrate thickness must be evaluated to appropriately account for these inward loads.
- Skyline Roofing panels utilize fastener mounting slots at 11" intervals.
- Basic Wind Speed Met is based on 2018 International Residential Code (IRC) code provisions (IRC Section R301.2.1) using the following assumptions: Slope >2:12, Wind exposure =B, Mean roof height ≤ 30', No topographic effects. These values only apply to projects that fall under the 2018 IRC. For applications beyond the assumptions above, please refer to IRC Section R301.2.1 for necessary adjustments, or consult a design professional for assistance.
- Outward Wind Load Capacities are taken from IAPMO-UES Building Code Compliance Report #ER-0309. For projects governed by the International Building Code (IBC), consult the Engineer of Record to determine if stated capacities meet or exceed the project's outward wind load requirements. The capacities stated in the table can also be used for IRC governed projects.

PROCEDURE FOR INSTALLING PANELS LESS THAN 40 FT. IN LENGTH

- Align the female edge of the first panel with the alignment line constructed along the start gable (See page 5, item 4). Allow the panel to overhang the eave 1". (*Illustration #3*)
- Check the uphill end of the panel (See the corresponding detail for proper panel position). Make sure the female edge of the panel remains 1/4" from the gable and the overhang is 1" from the eave.
- After the first panel is properly aligned, tack the gable end to the roof as in illustration #3. Then, fasten the panel along the male edge fastening flange. Refer to table #1 for the fastener spacing.
- Align the second panel female edge with the first panel male edge (*see illustration #4 page 10*). Make sure the panels are flush with each other at eave edge. *Note:* the panels overhang the eave by 1".

Illustration No. 3

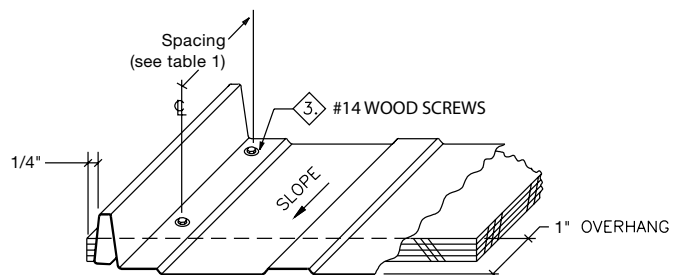

- Snap the panels together at the seam with light foot pressure. Work the seam together from the eave end toward the ridge. DO NOT work the seam from both ends toward the middle.
- After locking the panel seam, fasten the panel to the roof utilizing the fastening flange along the male edge (*See illustration #4*).

Panel Installation (continued)

7. Apply consecutive panels as in items #4 through #6 above.
8. Fasten the panels along the eave with #14 wood screws located along a straight line parallel to the eave and 3" up from the end of the panel. The fasteners should be evenly spaced (See *illustration #5*).

Illustration No. 4

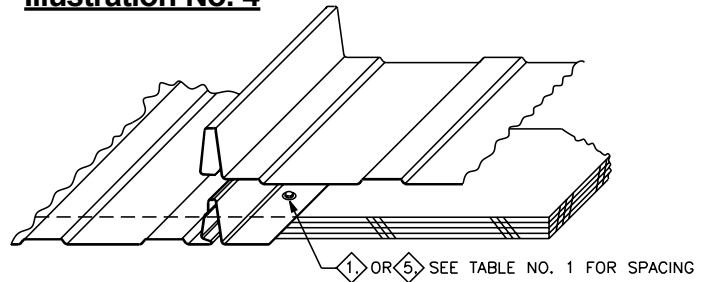

PANELS GREATER THAN 40 FT. IN LENGTH

1. Install eave flashing and fasten to the roof substrate. (See *Eave Flashing details*)
2. Align the female edge of the first panel with the alignment line constructed along the start gable (See *page 5 Item 4*). Check the uphill panel position and allow the panel to overhang the eave 1".
3. After the panel is aligned, fasten the panel along the eave with #14 wood screws in a straight line parallel to the eave and 3" up from the end of the panel (Illustration #5).
4. Install the long length Skyline Roofing clip so that the formed edge rests against the male leg (See *Illustration No. 6*). Make sure the clip is spaced every 24" o.c. along the panel.
5. Align the second panel female edge with the first panel male edge and make sure the panels are flush with each other at the eave edge.
6. Snap the panels together at the seam with light foot pressure. Work the seam together from the eave end toward the ridge. DO NOT work the seam from both ends toward the middle.
7. Apply consecutive panels following steps 3-6.
8. Install the gable flashings on both sides of the roof (Make sure the G16 flashing is used in both cases so that the panel is free to expand and contract. (See *"Start and End Gable" Flashings Details for installation*).

Illustration No. 5

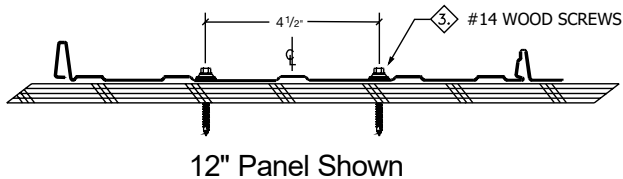

3. After the panel is aligned, fasten the panel along the eave with #14 wood screws in a straight line parallel to the eave and 3" up from the end of the panel (Illustration #5).
4. Install the long length Skyline Roofing clip so that the formed edge rests against the male leg (See *Illustration No. 6*). Make sure the clip is spaced every 24" o.c. along the panel.

Note: For 12" wide panels (Illustration No. 5) use two fasteners as shown. For 16" wide panels (Illustration No. 6) use three fasteners as shown.

Illustration No. 6

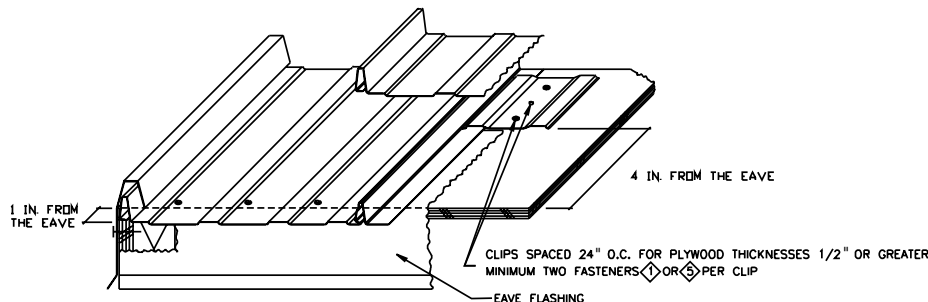

16" Panel Shown

Hip/Ridge Flashing

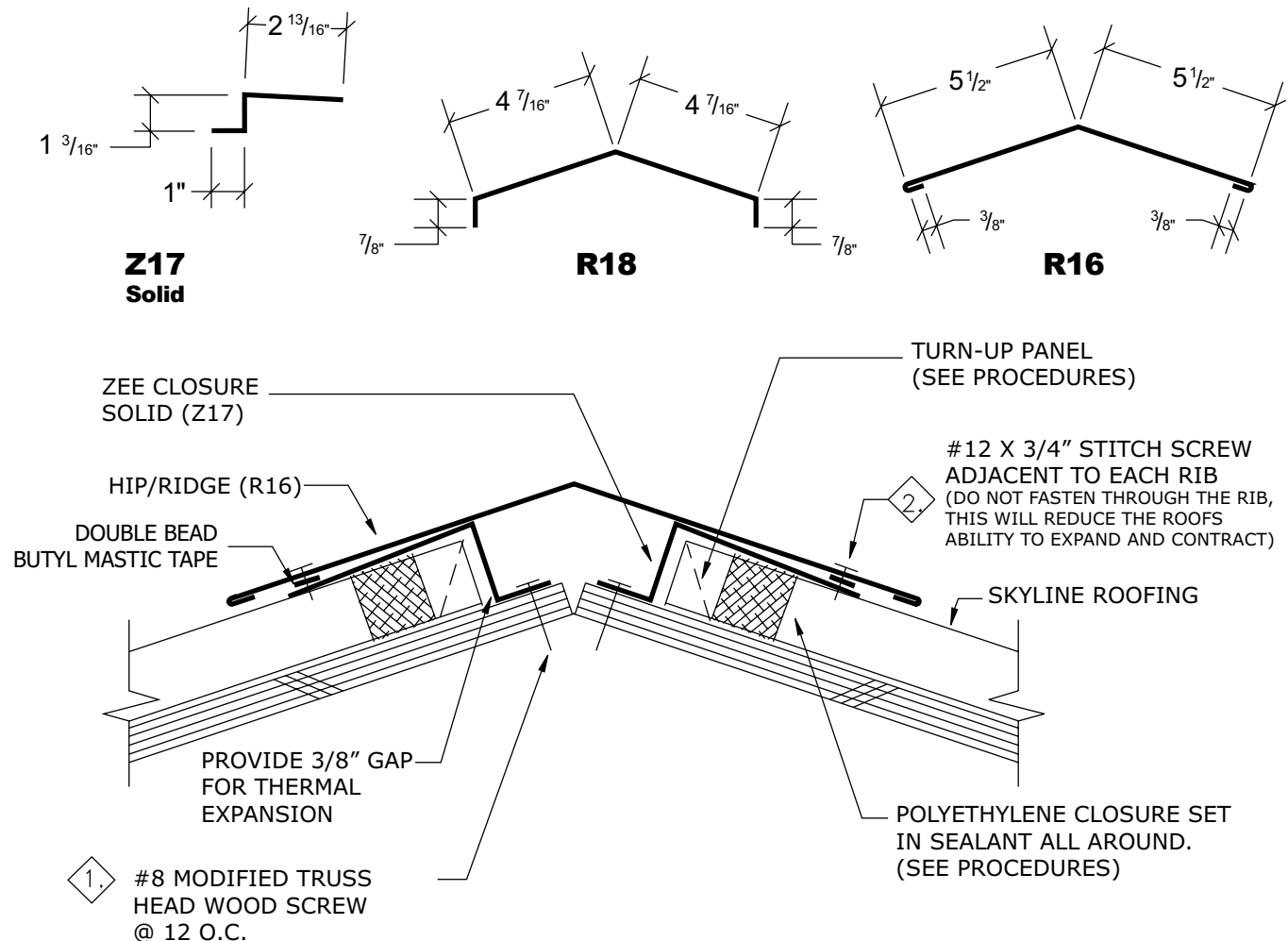

Procedures

- Locate the panels down from the ridge as required. Provide space between the zee closure "Z17" and the end of the panel to allow for expansion of the panel. Check the overhang at the eave. (See pg. 9).
- Caulk the bottom and sides of the polyethylene closure. Set the closure as shown above and caulk the top. The closure is optional if the panel is turned up and caulked at the sides near the rib.
- Attach the zee closure "Z17"(solid) at the top edge of the roof parallel to the ridge.
- Fasten the hip/ridge flashing "R16" to the zee using #12 x 3/4" stitch screws. (Adjacent to the panel ribs).
- Caulk, lap and rivet sequential flashings. (See pg. 49).

Note: "R16" is a standard ridge. A narrow ridge, "R18", is also available. If using narrow ridge, field notch with tin snips to fit over ribs. Attach "R18" to the zee closure with color-matched #12 x 3/4" stitch screws @ 12" o.c. adjacent to each panel rib.

Vented Ridge Flashing

Note: The gable flashing must be installed prior to installation of the ridge. (See page 23)

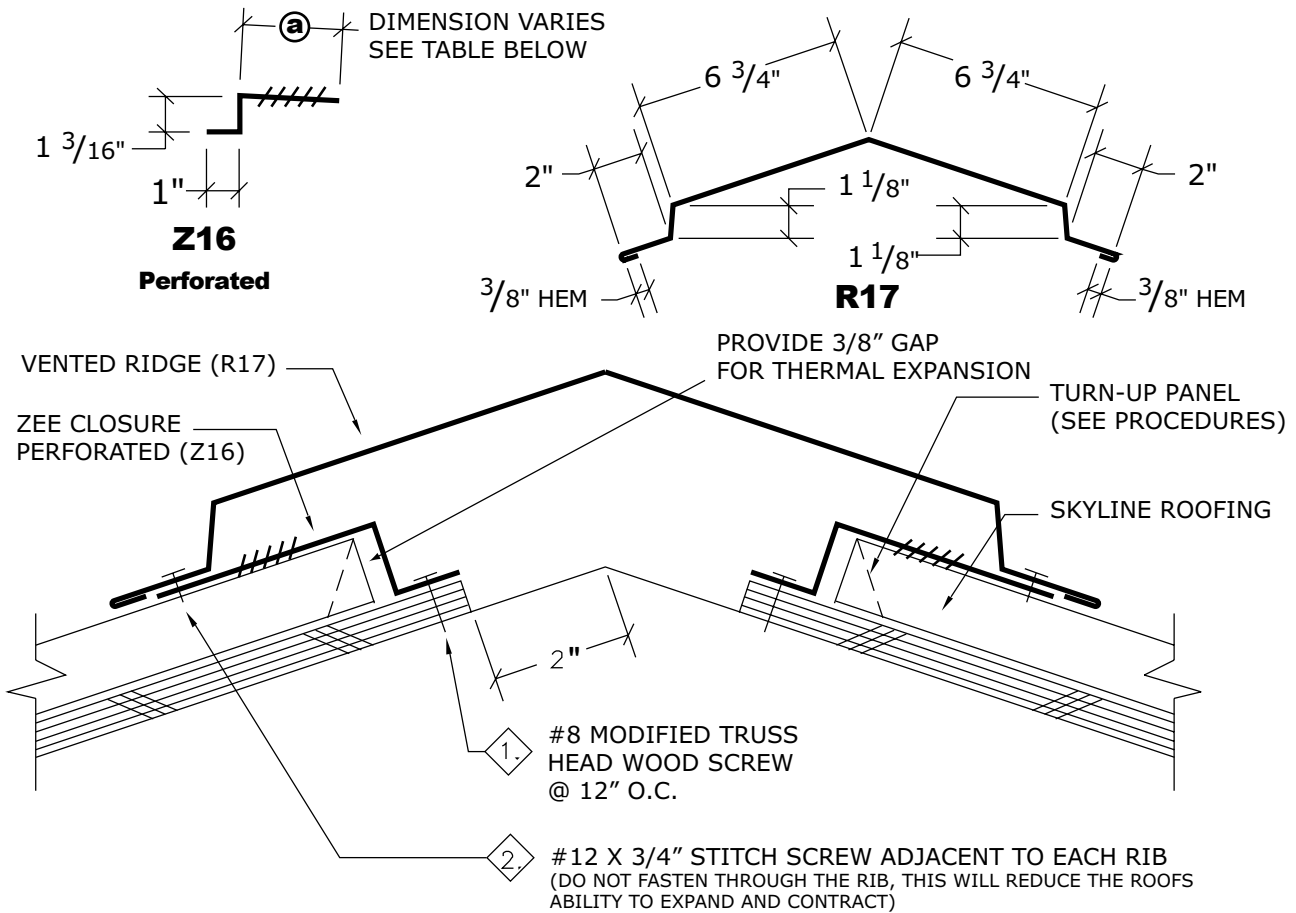

Procedures

- Substrate should be held back 2" from each side of the ridge.
- Locate the panels down from the edge of the substrate as required. Provide space between perforated zee closure "Z16" and end of panel to allow for expansion of the panel. Check the overhang at the eave. (See pg. 9).
- Turn-up panel and caulk at the sides near the ribs. For increased weather tightness add neoprene closure below panel turn-up.
- Attach the perforated zee closure "Z16" at the top edge of the plywood and parallel to the ridge.
- Fasten the vented ridge "R17" to the zee closure using #12 x 3/4" stitch screws. (Adjacent to the panel ribs).
- Caulk, lap and rivet sequential flashings. (See pg. 49).
- Close the ends of the ridge cap by slitting and folding material at each end, caulking joints, and fastening with rivets. (See pg. 13).

Roof Pitch	Dimension (a)
3:12-6:12	4½"
7:12-9:12	3¾"
10:12-12:12	3"

Vented Ridge Termination

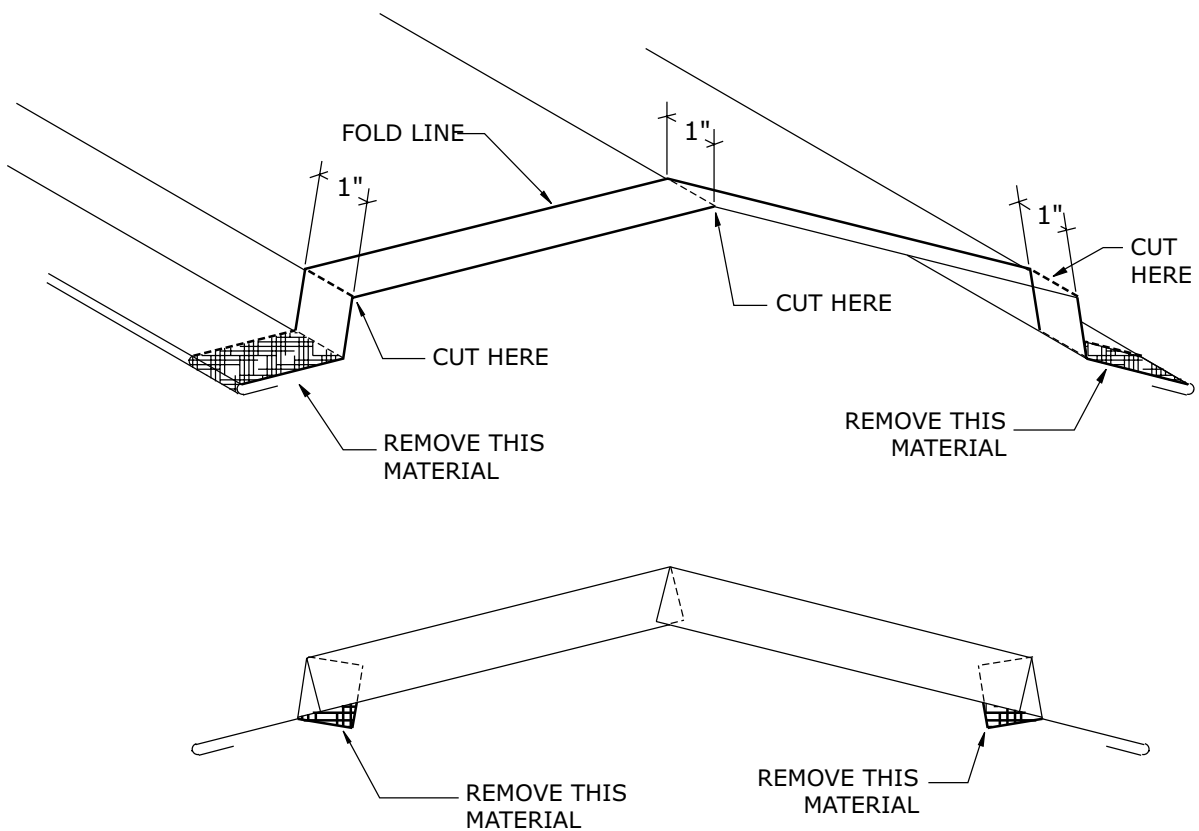
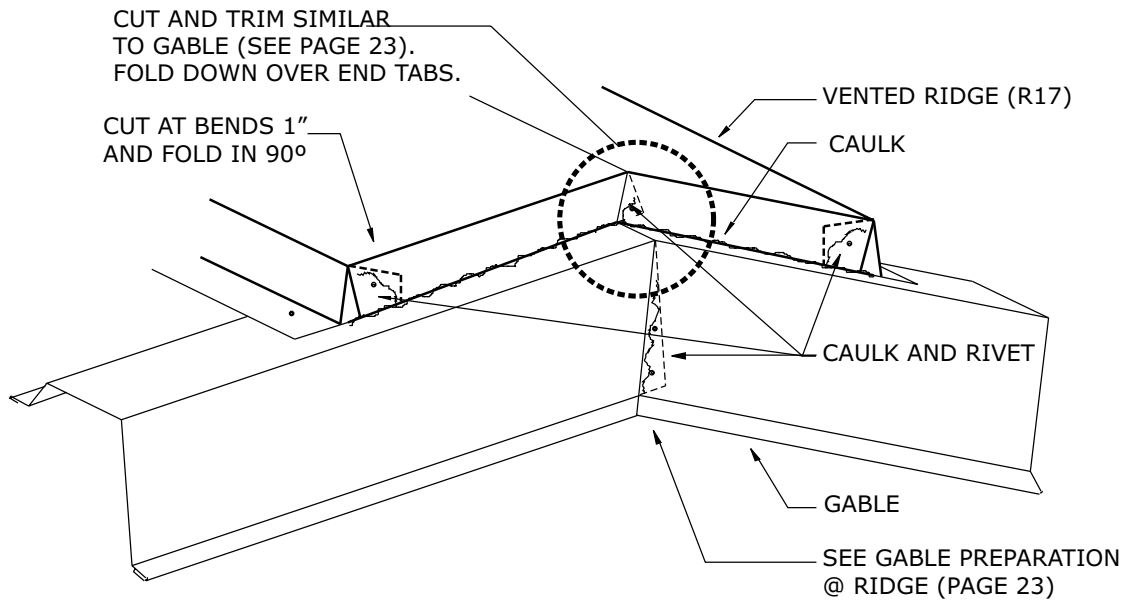

Valley Flashing

Note: This flashing must be installed prior to the panels.

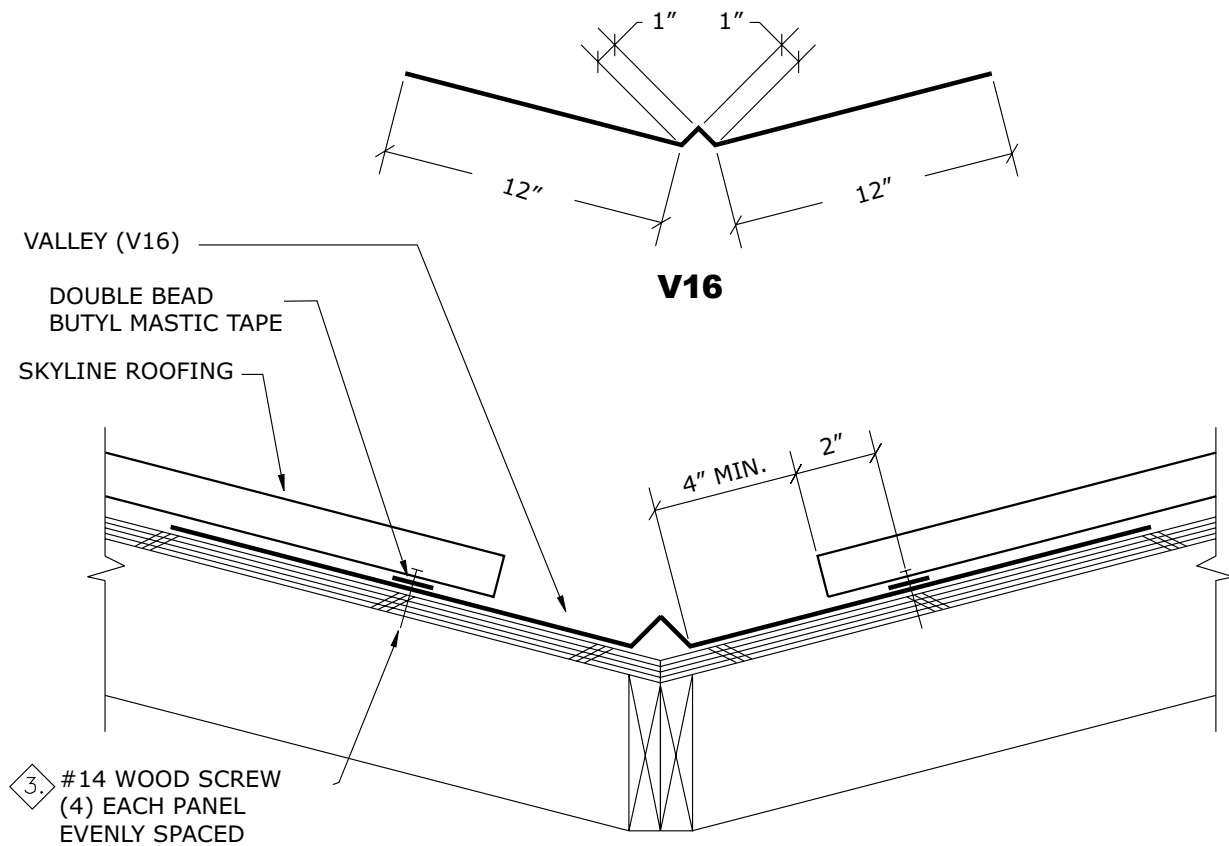

Procedures

- Place a second layer of 36" roof felt in the valley center line with 18" of felt on each side.
- Starting at the low end, trim and place the valley flashing "V16" so it overhangs the eaves 1". (See pg. 15).
- Caulk and over lap the subsequent valley flashings a minimum of 8".
- Parallel to the valley, place row of double bead butyl mastic tape spaced as shown.
- Field cut the panels holding a minimum of 4" back from the valley as shown. Larger valleys, without the center V, may be required in snow country installations.
- Fasten the panels to the substrate using (4) #14 wood screws, evenly spaced, insert 2" from the end of panel so they align with butyl mastic tape.

Note:

- Valley dimensions must be the proper width to account for slope, snow, ice and rain conditions. An underlayment such as a rubberized cold-applied membrane is recommended. The membrane is installed first, extending 3'-0" up from the center of the valley on each side, with felt overlapping the membrane.
- Refer to applicable building codes to ensure roof valley construction meets code requirements. Certain jurisdictions, like wildfire prone areas, may require different construction methods or materials.

Valley Termination

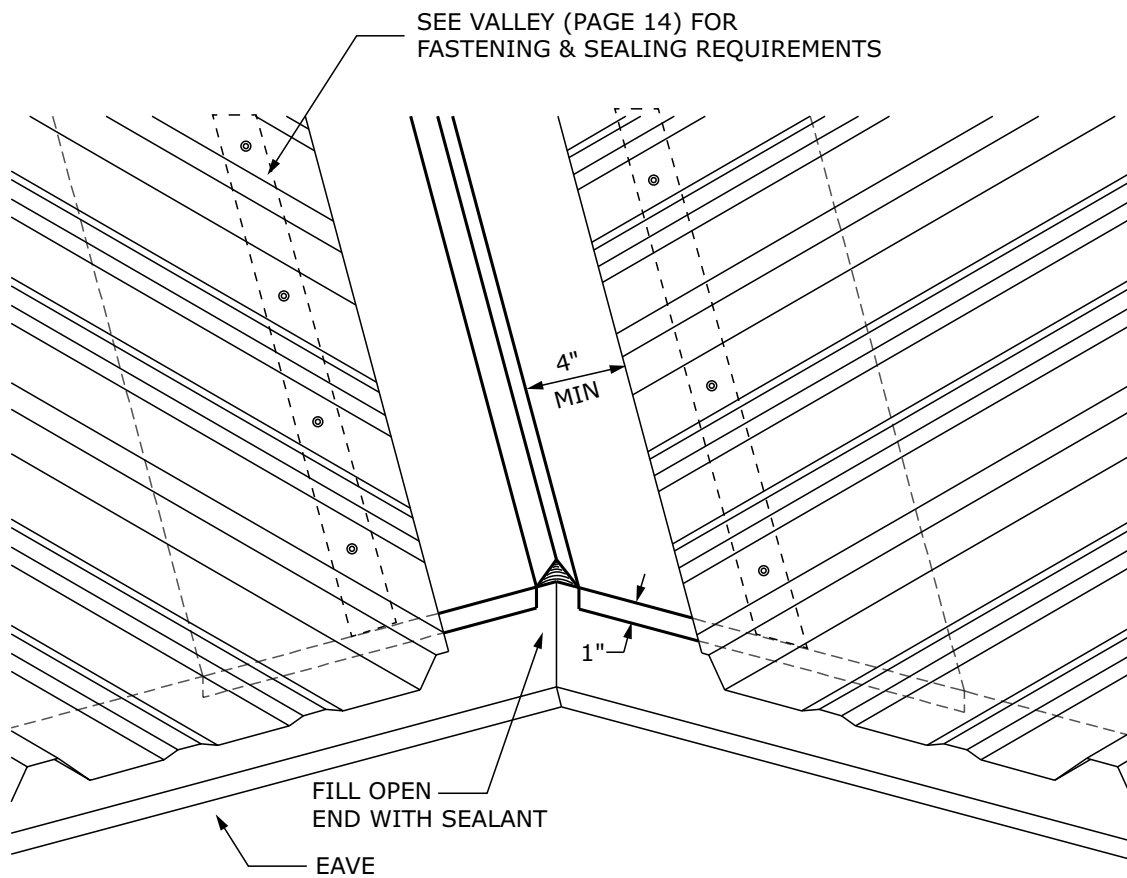
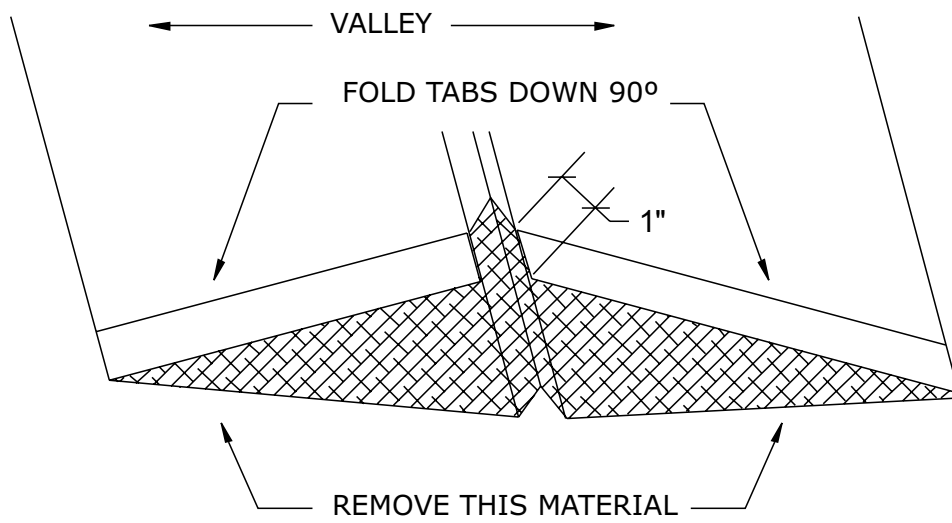

Eave Flashing

Note: This flashing must be installed prior to the panels.

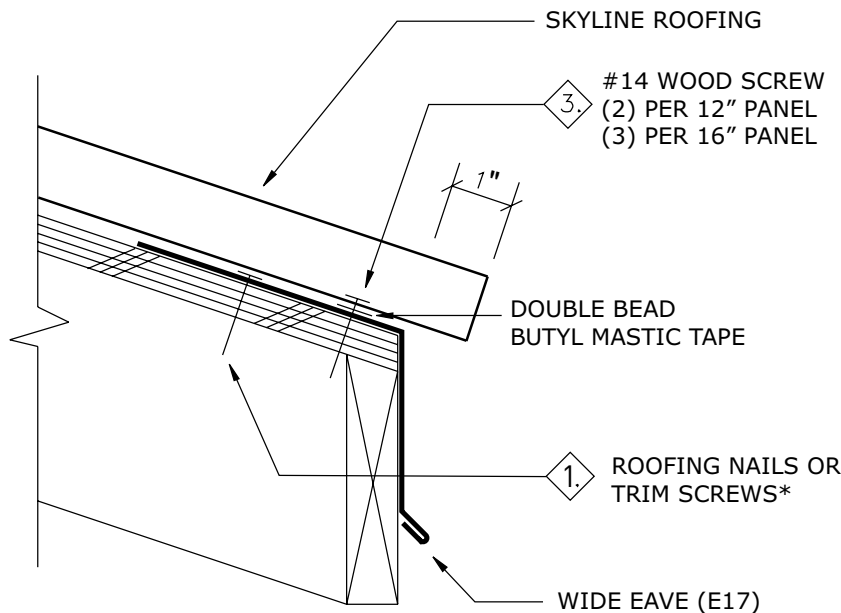
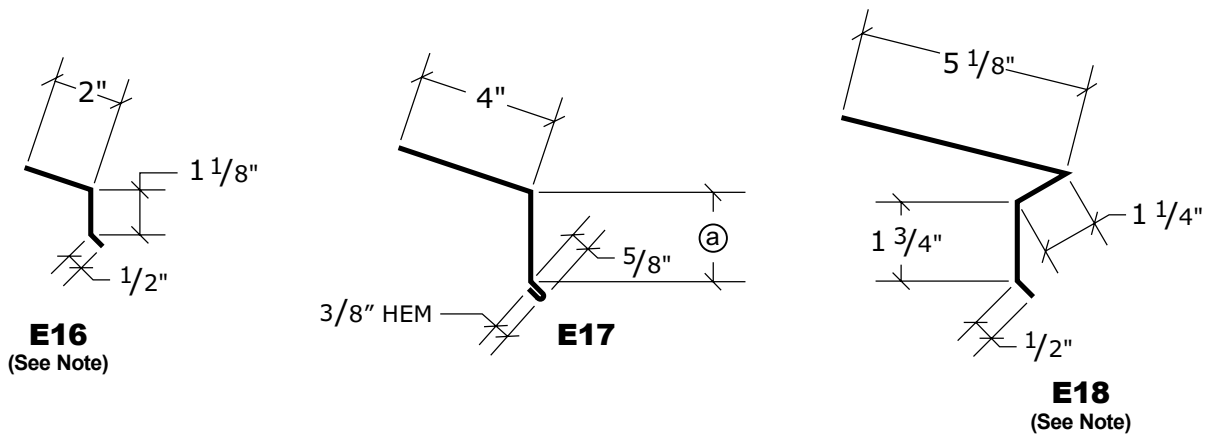

* To temporarily secure flashing prior to installing panels.

Roof Pitch	Dimension (a)
3:12 - 5:12	3 3/8"
6:12 - 7:12	3 3/8"
8:12 - 9:12	3 3/8"
10:12 - 12:12	4"

Procedures

- Attach the eave flashing "E17" using #10 pancake head wood screw or roofing nails evenly spaced at 24" o.c.
- Use a screwdriver to open the hem of the next flashing for approximately 4". (See pg. 49).
- Caulk and lap the flashing a minimum of 3" joining the hem. (See pg. 49).
- Panels should overhang the eave 1" minimum.

Note: "E17" is a wide eave. A narrow eave, "E16" is also available. "E18" is a snow eave designed for snow country. Note that E16 & E18 flashings do not line up with standard gable trims (G16 & G17). Heavy weather conditions may require a rubberized cold-applied membrane underlayment. See notes on page 14 for installation techniques.

Eave Flashing Preparation

Step One

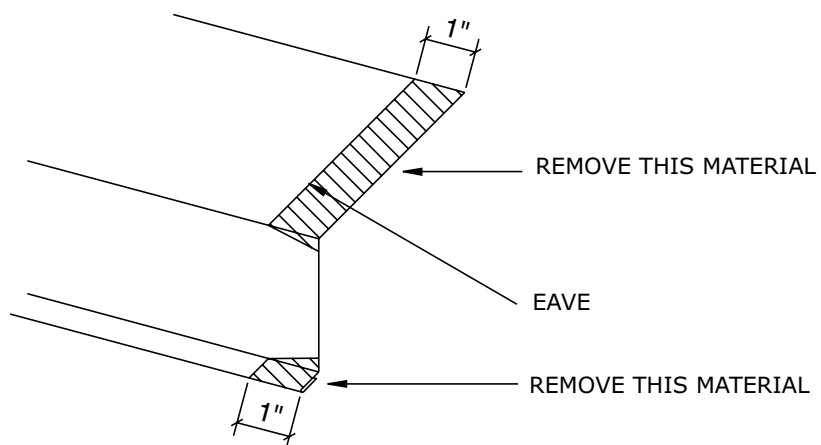

Step Two

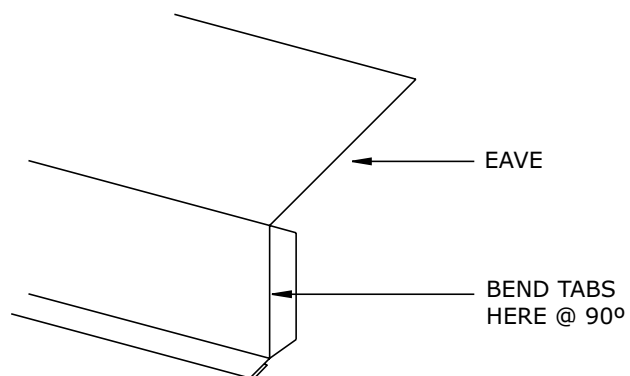

Eave with Gutter

Note: This flashing must be installed prior to the panels.

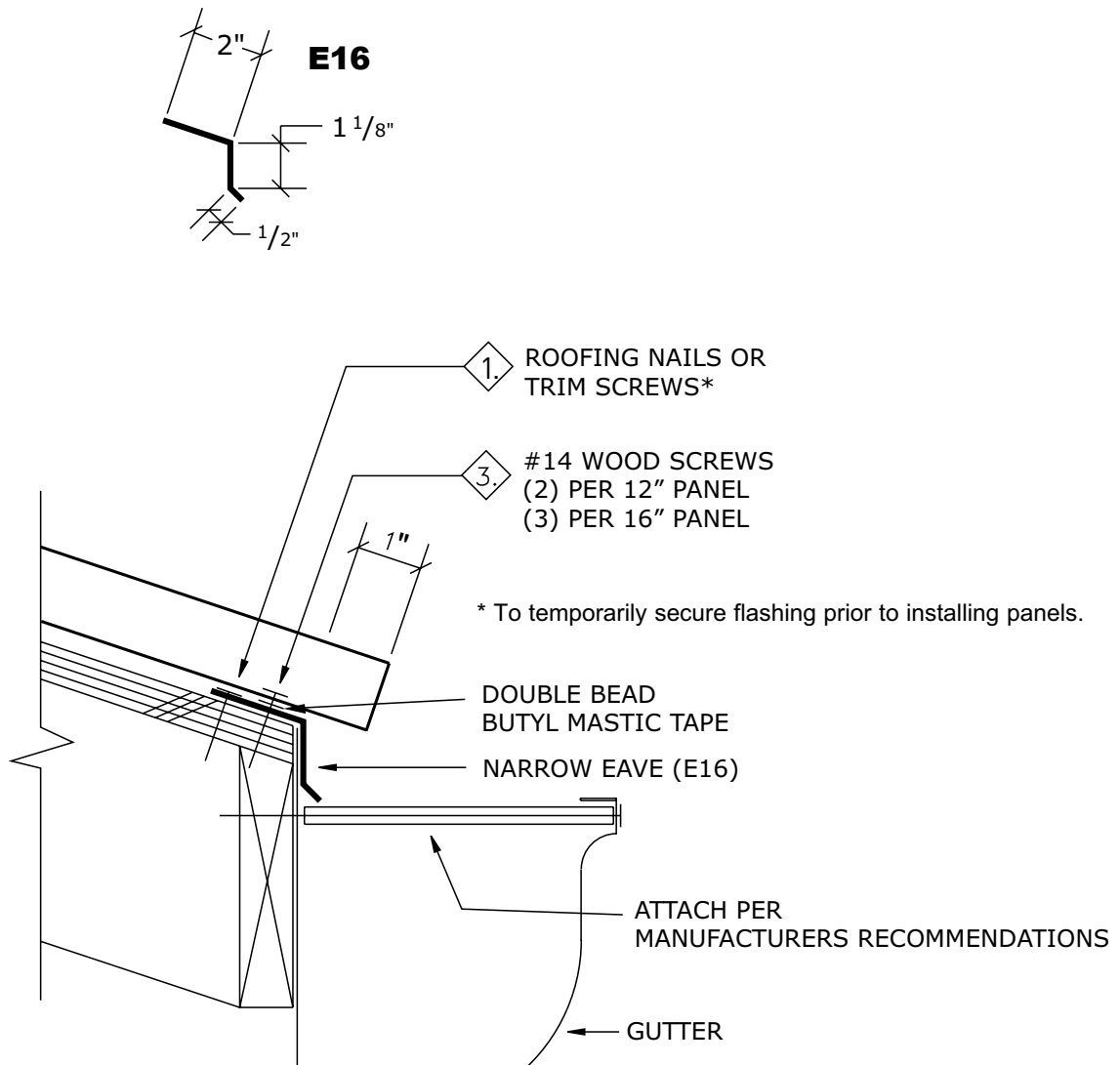

Procedures

- Carpentry must be complete as indicated prior to installation of the flashing.
- Attach eave flashing "E16" using #10 pancake head wood screw or roofing nails evenly spaced at 24" o.c.
- Use a screwdriver to open the hem of the next flashing for approximately 4". (See pg. 49).
- Caulk and lap the flashing a minimum of 3" joining the hem. (See pg. 49).
- Panels should overhang the eave 1" minimum.
- ASC Building Products recommends that a licensed gutter contractor install the gutter.

Start Gable Flashing

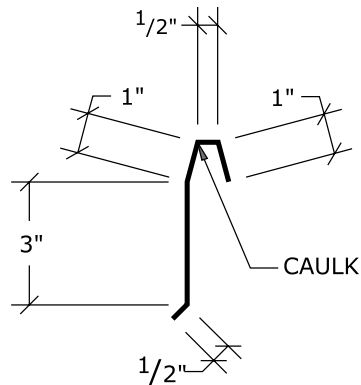

G16

(For panels longer than 40 ft.)

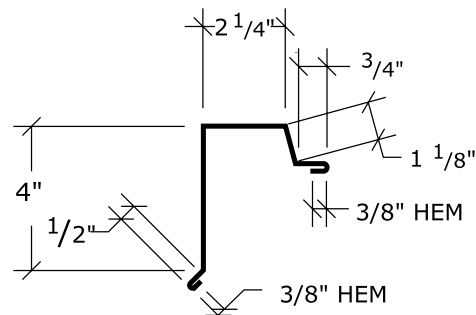

G17

(For panels shorter than 40 ft.)

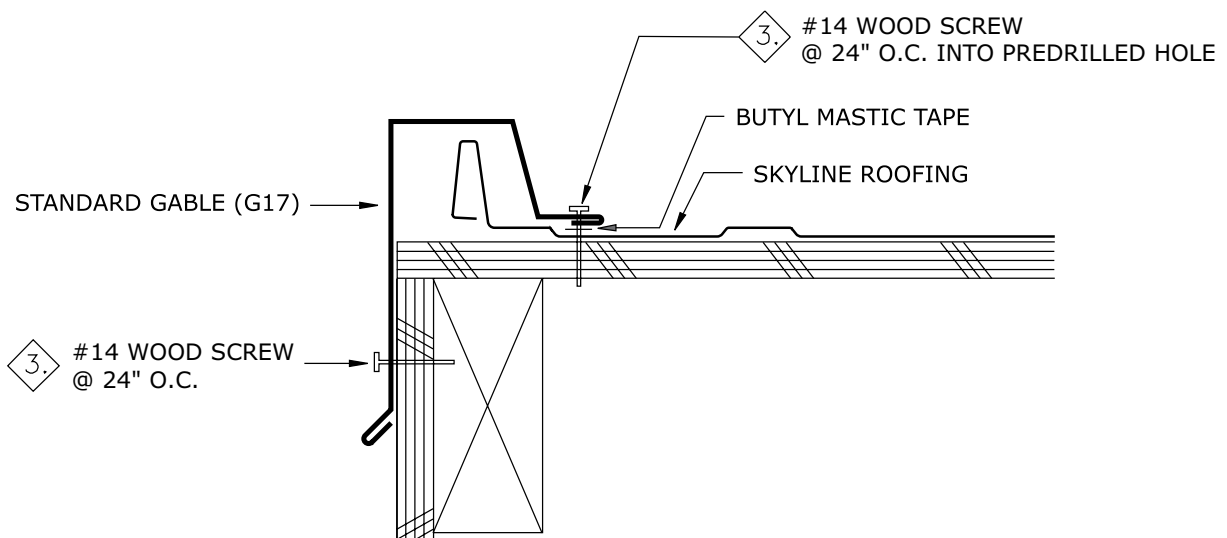

Procedures

- Place the first roof panel according to the instructions on pages 5-6 & 9.
- Place butyl mastic tape along the gable flashing's flange as shown.
- Install the gable flashing "G17" by placing it firmly over the rib and predrilling holes 24" o.c. then fasten using color matched wood screws. If using the narrow gable "G16" do not fasten. (See Note).
- Caulk and lap the flashing a minimum of 3" hooking the hem. (See pg. 49).
- Mitre cut the flashing at the peak to join each side at the ridge. (See pg. 23).
- Snip and fold the gable at the eave to close the end. Use rivets to fasten. (See pgs. 13, 17, & 22).

Note: If using the narrow gable "G16" do not fasten to panel, only to the structure. Narrow gable flashing fits snug against panel rib. Use "G16" for long length Skyline Roofing applications

End Gable Flashing

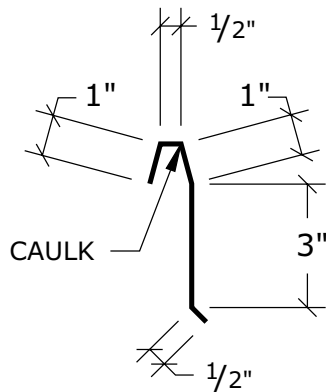

G16
(For panels longer than 40 ft.)

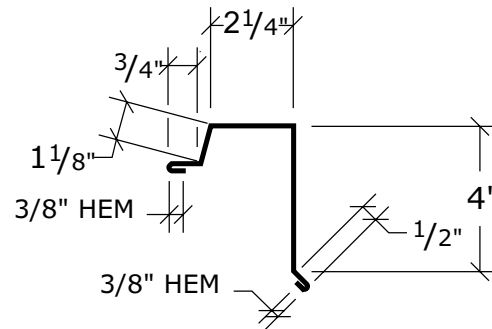

G17
(For panels shorter than 40 ft.)

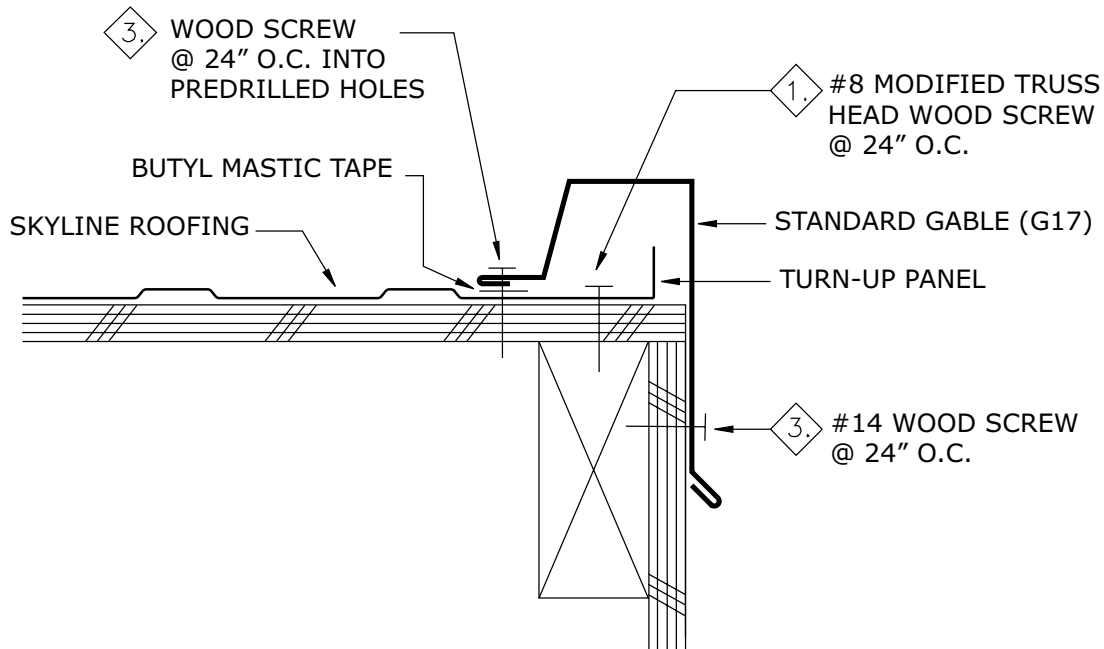

Procedures

- Trim the panel 1/2" in and parallel with the edge of the roof.
- Place butyl mastic tape along the gable flashing's flange as shown.
- Install the gable flashing "G17" by placing it firmly over the rib and predrilling holes 24" o.c. then fasten using color matched wood screws. If using the narrow gable "G16" do not fasten. (See Note).
- Caulk and lap the flashing a minimum of 3" hooking the hem. (See pg. 49).
- Mitre cut the flashing at the peak to join each side at the ridge. (See pg. 23).
- Snip and fold the gable at the eave to close the end. Use rivets to fasten. (See pgs. 13, 17, & 22).

Notes:

- If using the narrow gable "G16" do not fasten to panel, only to the structure. Narrow gable flashing fits snug against panel rib, or panel edge turned-up in the field.
- Gable flashing should be dimensioned to match peak, ridge, and eave flashings.
- Use "G16" for Skyline Roofing longer than 40 ft.

Gable/Ridge Transition

Similar to Gable/Endwall Transition

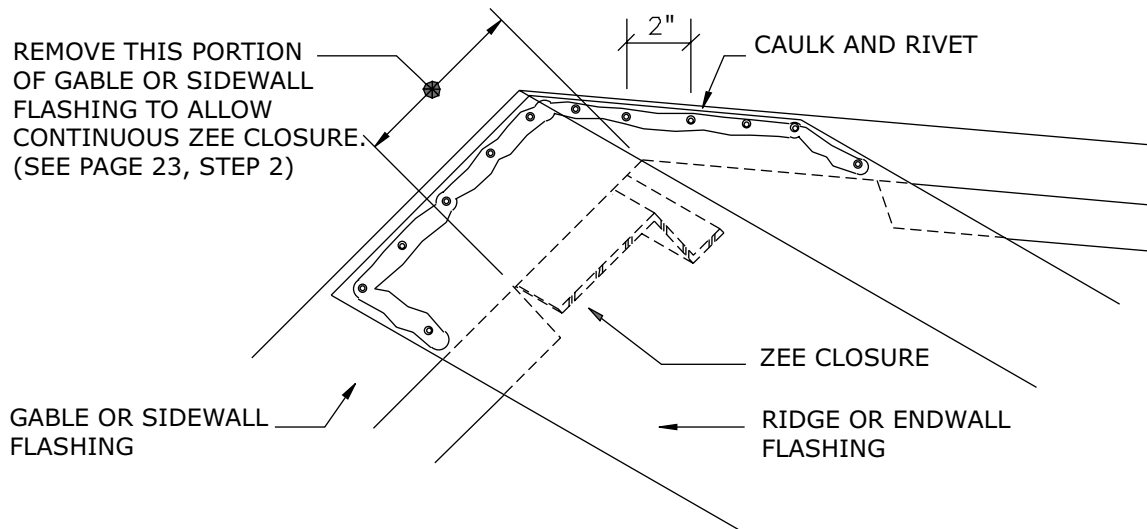

Gable Corner at Eave

See page 22 for instructions

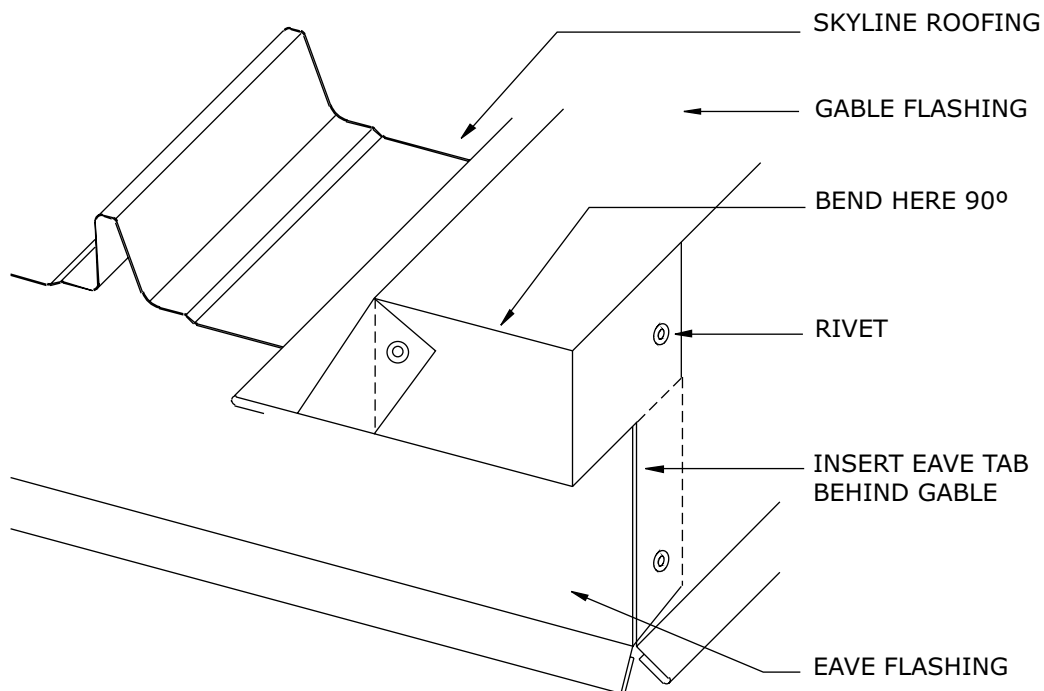

Gable Flashing Preparation

Step One

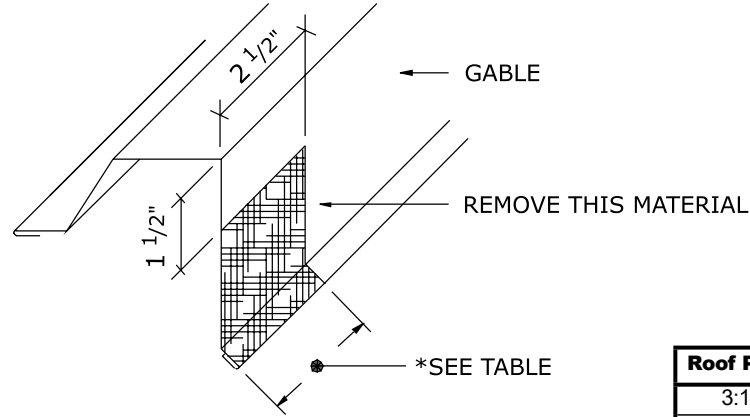

Roof Pitch	Dimension
3:12	1 1/8"
3 1/2:12	1 3/4"
4:12	1 5/8"
5:12	1 7/16"
6:12	1 1/4"
12:12	0"

Step Two

Note: Length of gable must extend 2 1/2" past eave fascia.

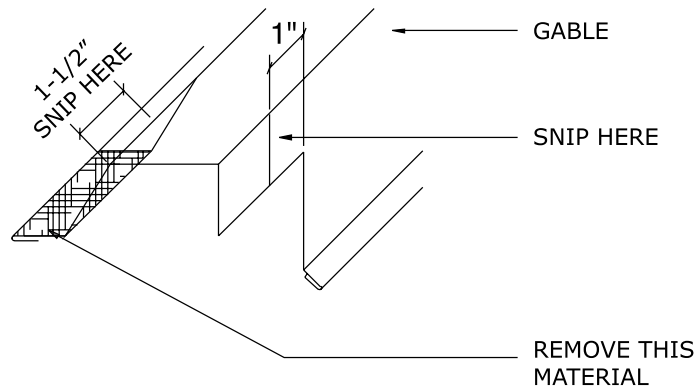

Step Three

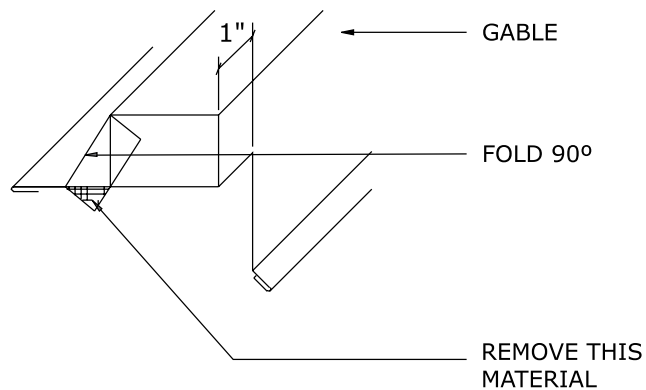

Gable Flashing Preparation at Ridge

Step One

Remove a pie-shaped piece from the gable flashing as shown below.

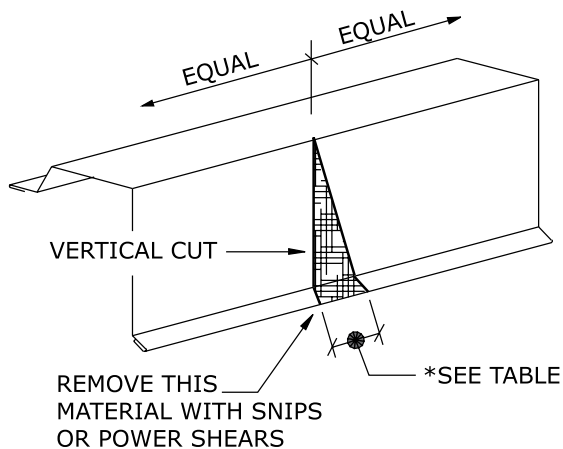

Roof Pitch	Dimension*
3:12	1 ¹ / ₁₆ "
3½:12	1 ¹ / ₄ "
4:12	1 ¹ / ₁₆ "
5:12	1 ³ / ₄ "
6:12	2 ³ / ₁₆ "
12:12	4 ⁷ / ₁₆ "

* Dimensions only apply to G16 and G17 Gable Flashing

Step Two

Notch out the downturn leg on the gable as shown below.

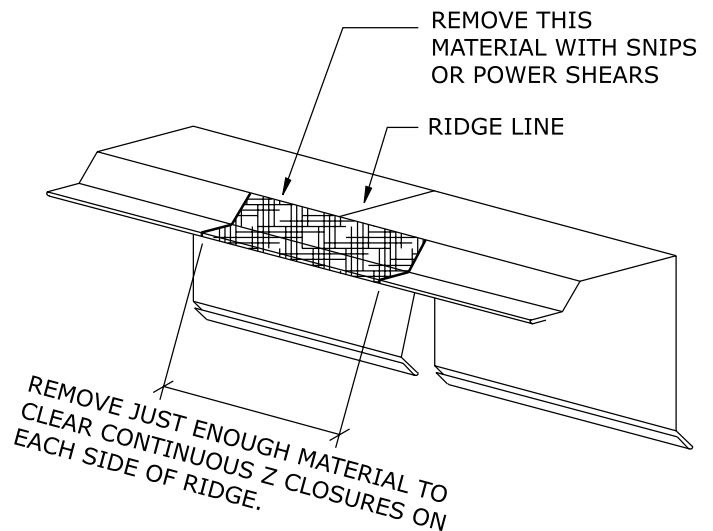

Step Three

Note: See page 13 for final steps

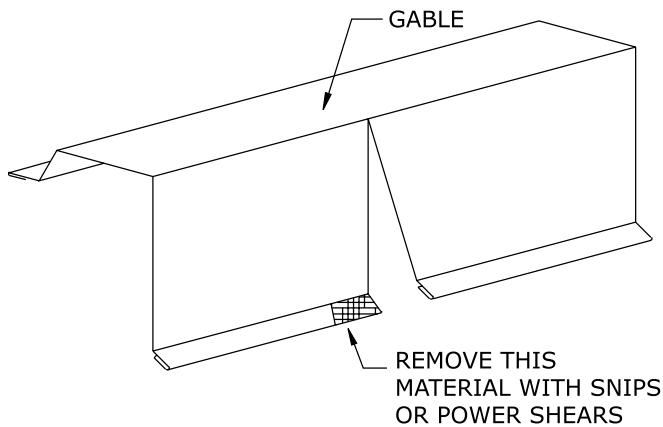

Step Four

Center the flashing on the ridge at the gable and bend to roof pitch

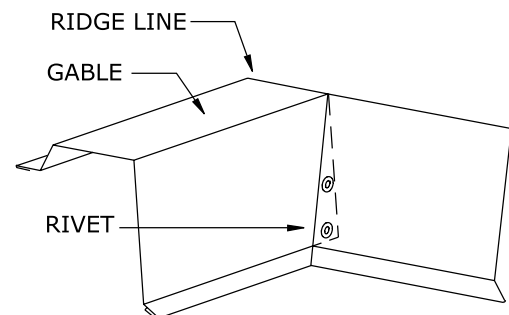

Note: Zee Closure "Z16" (perforated) or "Z17" (solid) must be in place prior to installation of the ridge piece.

Peak Flashing

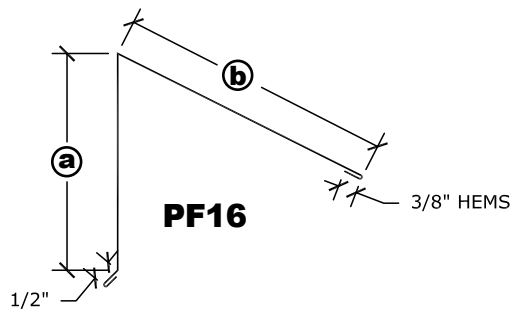

PF16 Roof Pitch	Dimension (a)	Dimension (b)
3:12-5:12	4-3/8"	6"
6:12-7:12	4-3/4"	6-1/2"
8:12-9:12	5-1/8"	6-3/4"
10:12-12:12	5-5/8"	7-3/8"

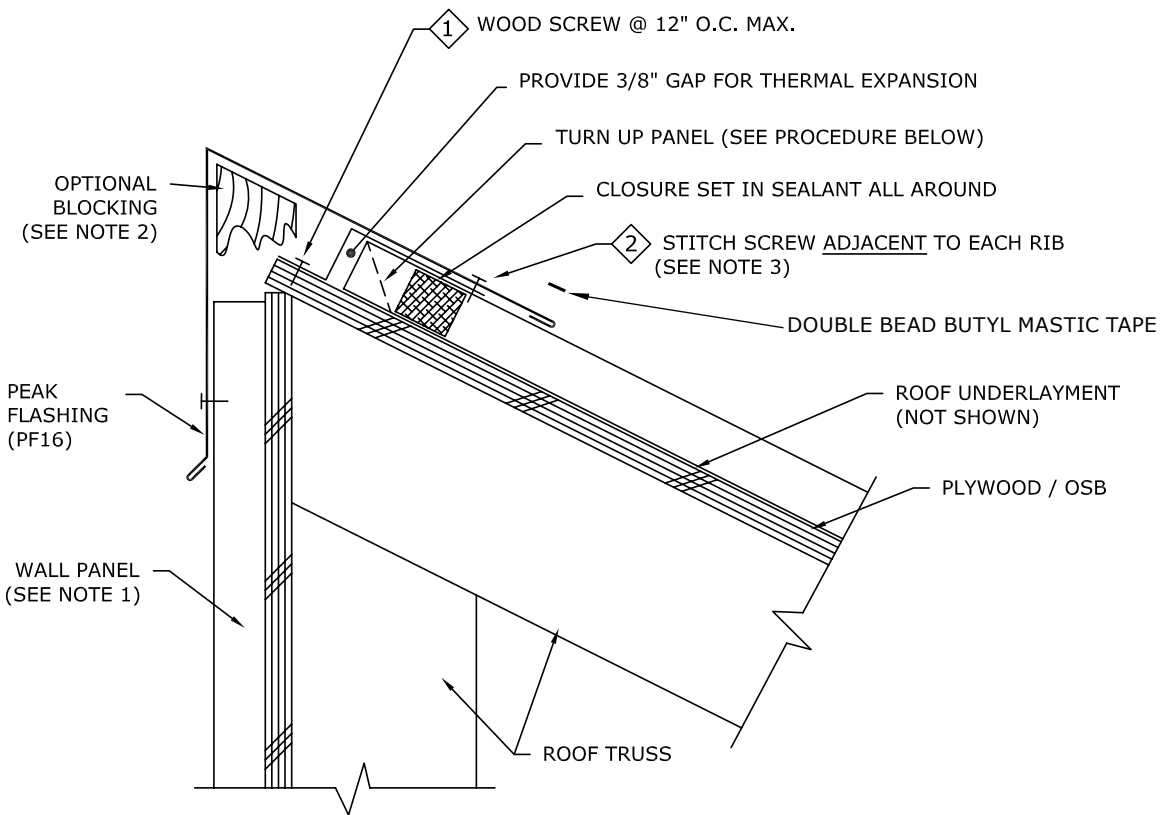
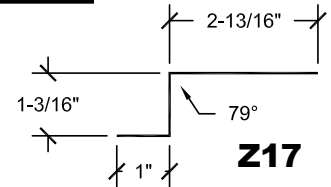

Procedures

- Locate the panels down from the edge of the substrate as required. Provide 3/8" space between zee closure and end of panel to allow for panel thermal expansion. Check overhang/ alignment at the eave. Review eave detail for additional information.
- Turn up the panel and caulk at the sides near the ribs.
- Closure (optional if panel end is turned up and sealed along ribs): Caulk bottom and sides of closure and set closure into place as shown in view.
- Attach the zee closure (Z17) at the top edge of the plywood and parallel to the ridge.
- Fasten the peak flashing (PF16) to the zee closure using #12 x 3/4" stitch screws adjacent to the panel ribs (See note 3).
- Caulk, lap, and rivet sequential flashings (See pg. 49).
- Close the ends of the peak at gable ends by slitting and folding material at each end, caulking joints, and fastening with rivets.

Notes:

1. Peak flashing dimensions noted on this installation detail based on nominal 1" thick wall facing. Different wall panel thicknesses may require some adjustments to peak flashing dimensions and/or positioning of roof assembly components.
2. Additional blocking may be required at peak to support peak flashing.
3. Do not screw into the panel ribs, this will restrict the roof's ability to expand and contract.

Vented Peak Flashing

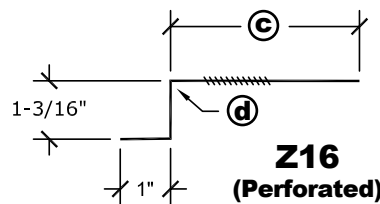
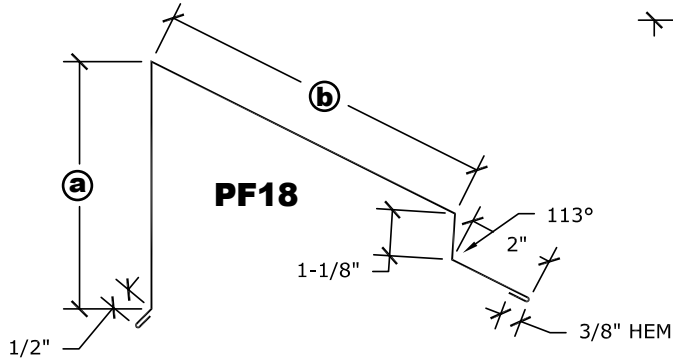

Z16 Roof Pitch	Dimension ©	Dimension d
3:12-6:12	4-1/2"	83°
7:12-9:12	3-3/4"	81°
10:12-12:12	3"	79°

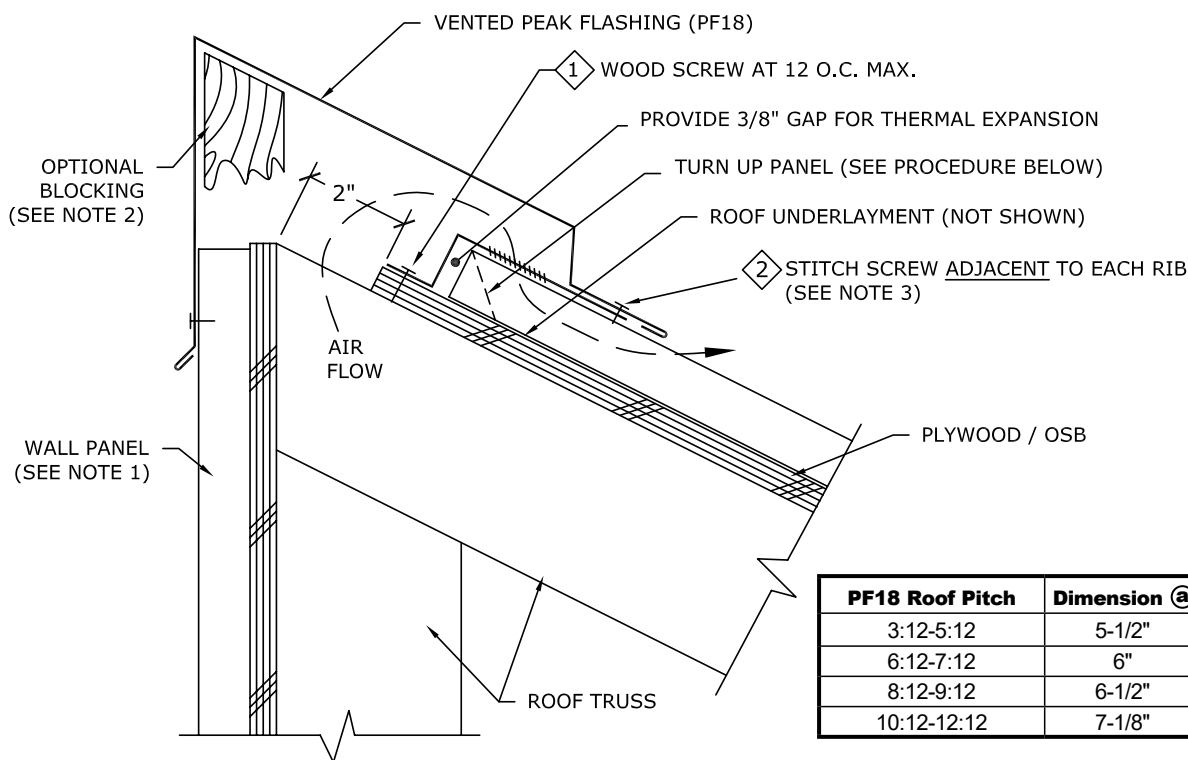

PF18 Roof Pitch	Dimension a	Dimension b
3:12-5:12	5-1/2"	8"
6:12-7:12	6"	8"
8:12-9:12	6-1/2"	8-3/8"
10:12-12:12	7-1/8"	9-1/4"

Procedures

- Substrate should be held back 2" from peak for venting.
- Locate the panels down from the edge of the substrate as required. Provide 3/8" space between perforated zee closure and end of panel to allow for panel thermal expansion. Check overhang/ alignment at the eave. Review eave detail for additional information.
- Turn up the panel and caulk at the sides near the ribs.
- Attach the perforated zee closure (Z16) at the top edge of the plywood and parallel to the ridge.
- Fasten the vented peak flashing (PF18) to the zee closure using stitch screws adjacent to the panel ribs (See note 3).
- Caulk, lap, and rivet sequential flashings (See pg. 49).
- Close the ends of the peak at gable ends by slitting and folding material at each end, caulking joints, and fastening with rivets.

Notes:

1. Peak flashing dimensions noted on this installation detail based on nominal 1" thick wall facing. Different wall panel thicknesses may require some adjustments to peak flashing dimensions and/or positioning of roof assembly components.
2. Additional blocking may be required at peak to support peak flashing.
3. Do not screw into the panel ribs, this will restrict the roof's ability to expand and contract.

Sidewall Flashing

For panels shorter than 40 feet.

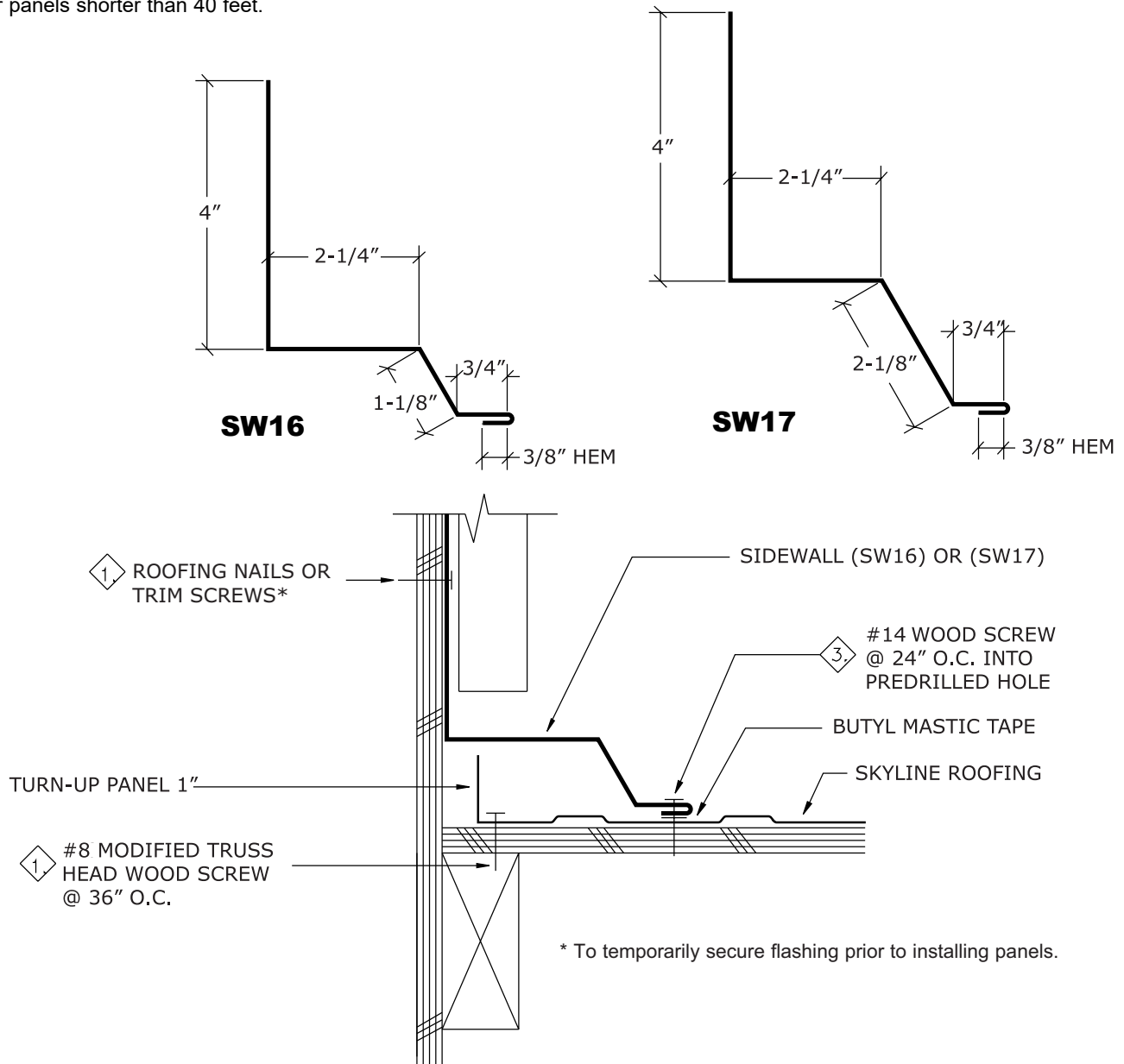

Procedures

- The roof should be installed prior to the siding.
- Trim the panel 1/2" in and parallel with the wall.
- Place butyl mastic tape along the sidewall flashing's flange as shown.
- Install the sidewall flashing "SW16" (when used with a standard endwall) by placing it firmly on the roofing panel and fastening with the fasteners indicated.
- Caulk and lap the flashing a minimum of 3" joining the hem. (See pg. 49).
- See page 28 on closing the end of the flashing.
- When using a sidewall flashing in conjunction with a vented endwall condition, increase the 1 1/8" leg on sidewall flashing, "SW16", to 2-1/8" ("SW17").

Note: Do not use this detail if panels are greater than 40 ft.

Sidewall Flashing

For panels greater than 40 feet.

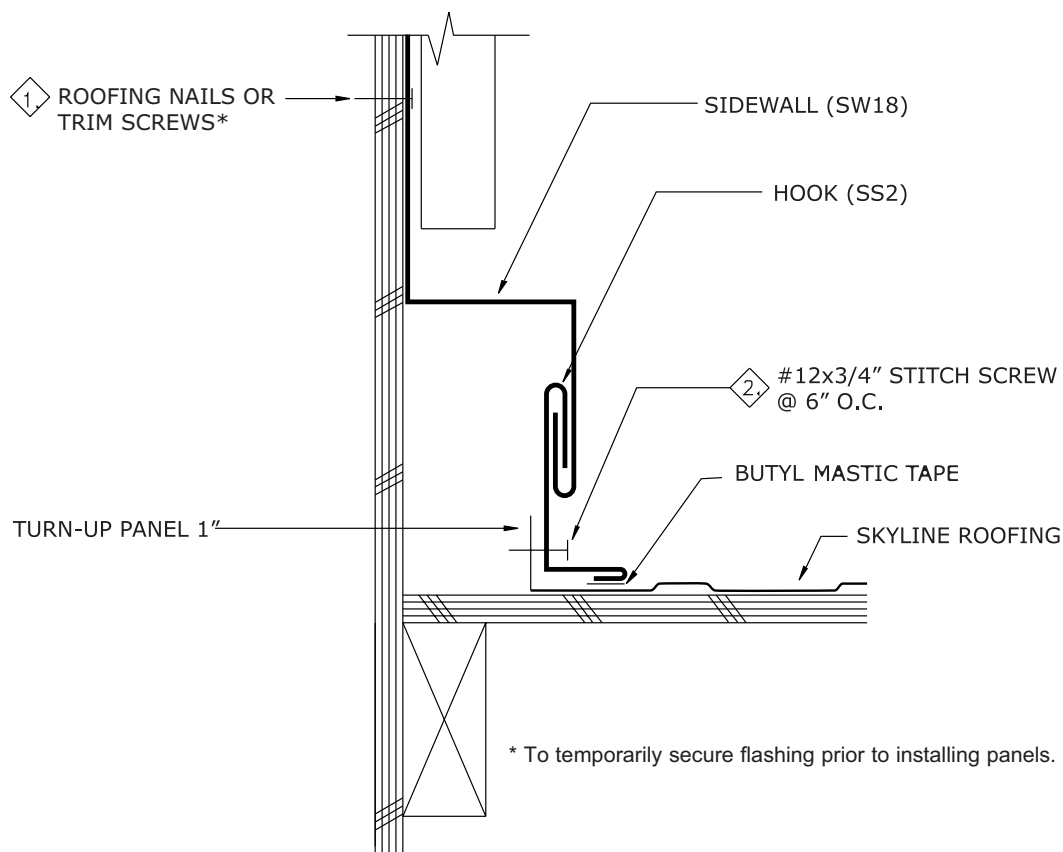
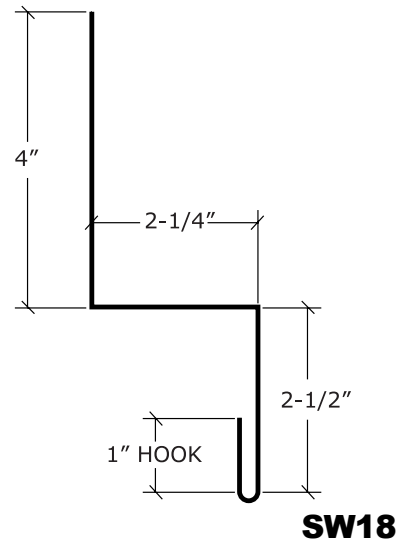
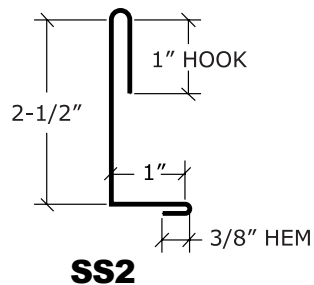

Procedures

- The roof and flashings should be installed prior to siding.
- Trim the panel 1" in and parallel with the wall.
- Turn up the panel 1" from the edge of the panel as shown.
- Apply mastic tape to the hook (SS2) before fastening.
- Fasten hook (SS2) to the turn-up. Make sure panel is able to expand and contract.
- See page 28 on closing the end of the flashing.
- Install the sidewall flashing (SW18) by hooking it into the hook (SS2) and then fastening it to the wall.

Closing Sidewall Flashing

For panels shorter than 40 feet.

Step One

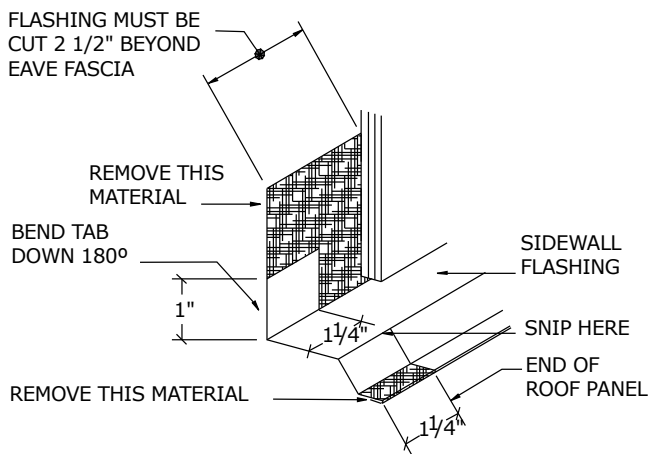

For panels longer than 40 feet.

Step One

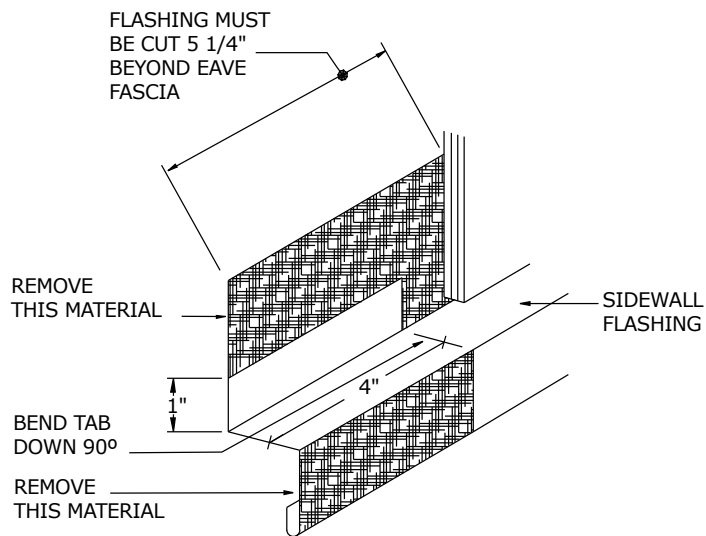

Step Two

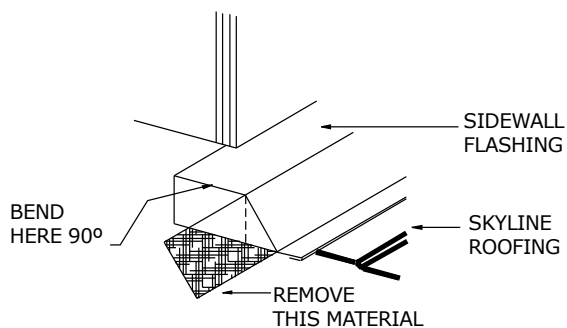

Step Two

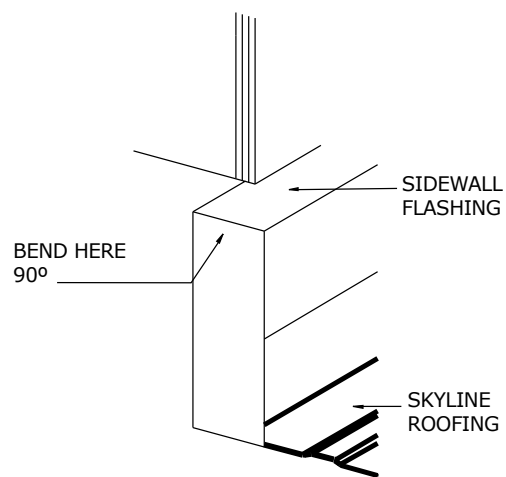

Endwall Flashing

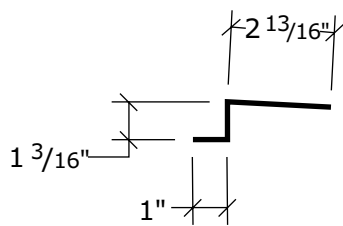

Z17
Solid

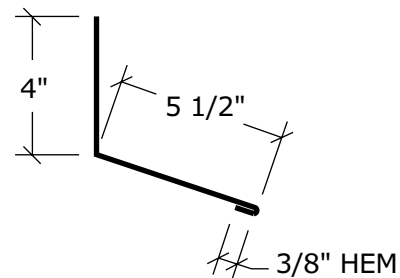

EW16

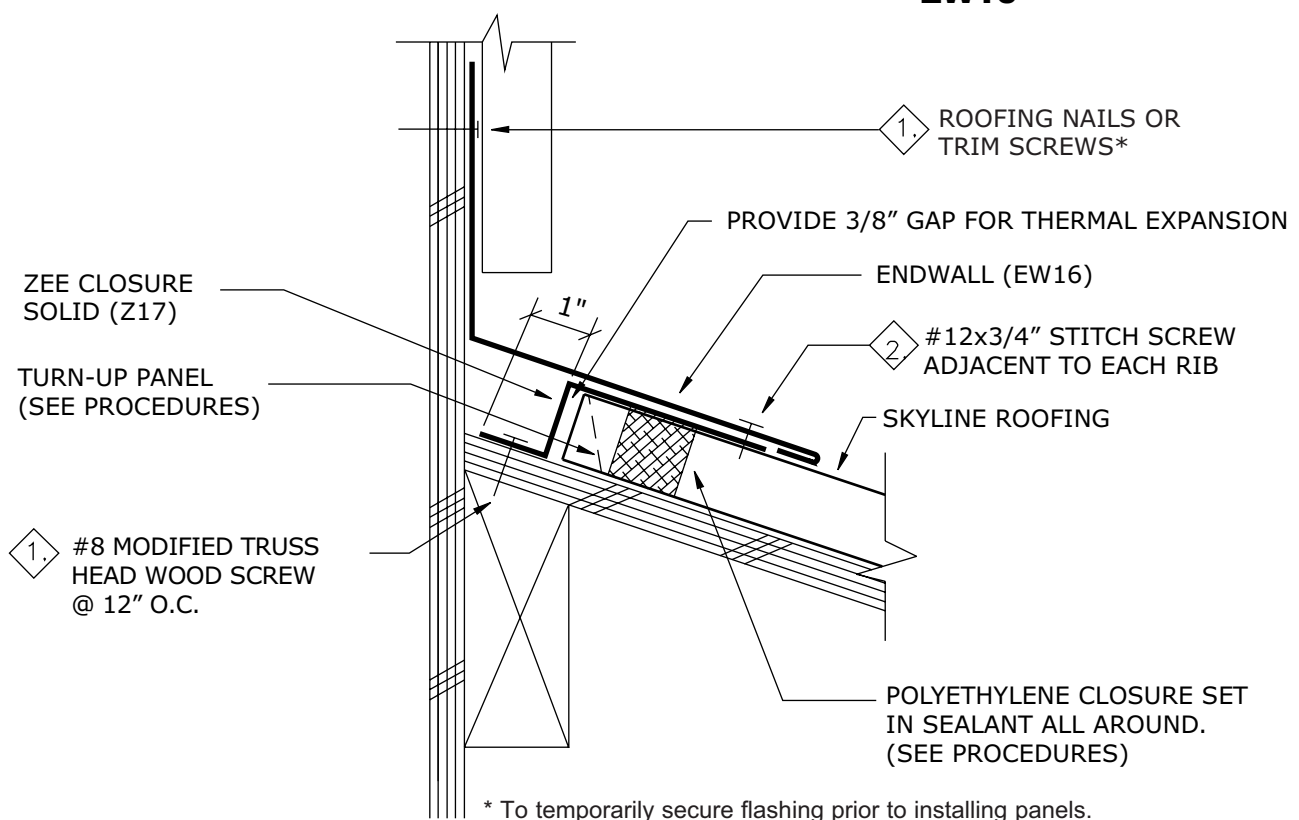

Procedures

- Locate the panels down from the endwall as required.
- Caulk the bottom and sides of the polyethylene closure, set the closure as shown above and caulk the top. The closure is an option if the panels are turned-up and caulked at the sides near the ribs.
- Attach the zee closure "Z17" (solid) at the top edge of the roof and parallel to the endwall.
- Provide space between the zee closure "Z17" and the end of the panel to allow for expansion of the panel.
- Fasten the endwall "EW16" with pancake head wood screws or roofing nails at 24" o.c.
- Fasten the endwall "EW16" to the zee using #12 x 3/4" stitch screws at each rib (Adjacent to the panel ribs).
- Caulk, lap and rivet sequential flashings. (See pg. 49).

Vented Endwall Flashing

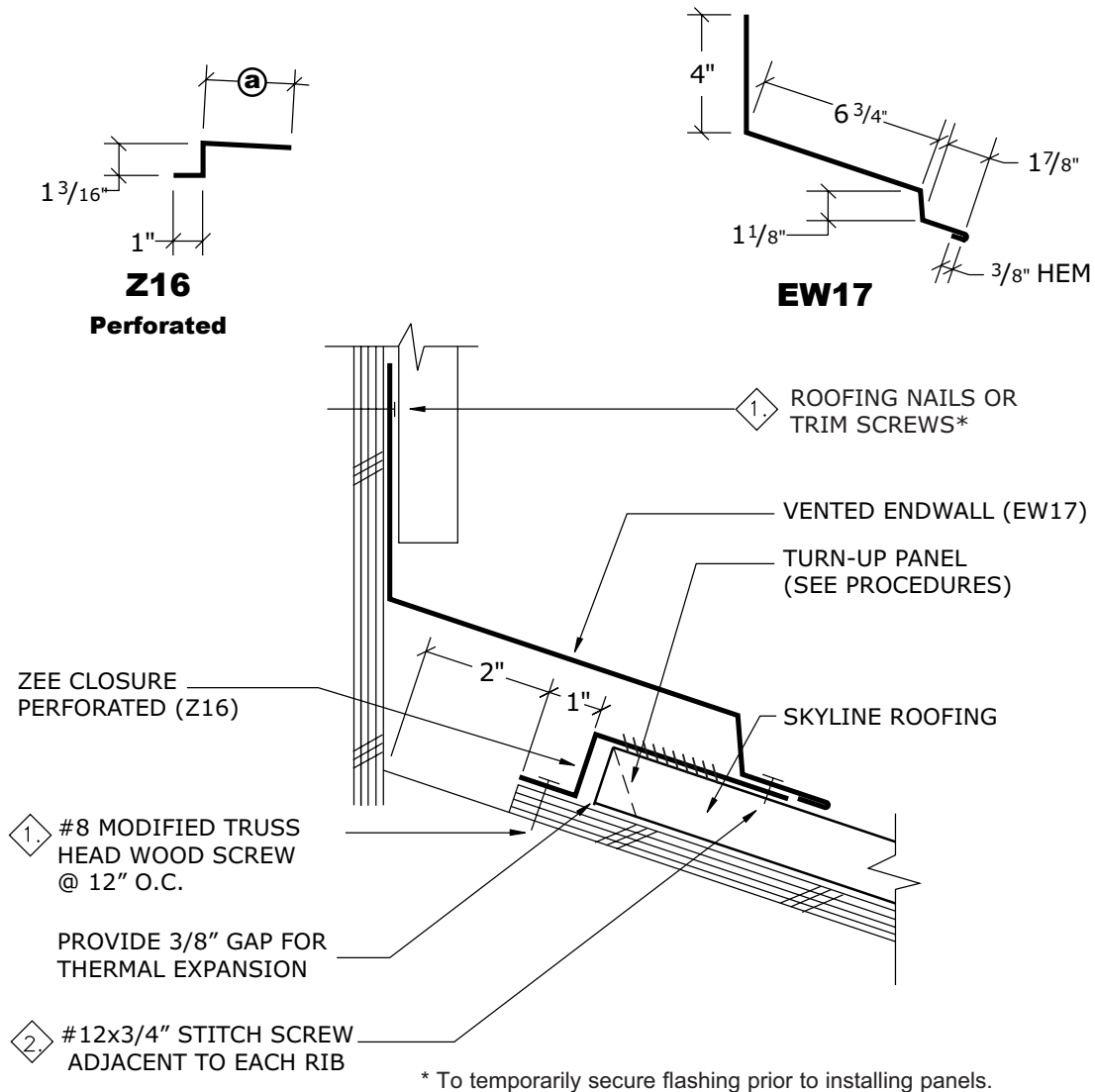

Procedures

- Substrate should be held back 2" from the wall.
- Locate the panels down from the edge of the substrate as required. Provide space between the zee closure "Z16" and the panel to allow for expansion of the panel.
- Turn-up pan of panel and caulk at the sides near the ribs. For increased weather tightness add a neoprene closure below panel turn-up.
- Attach the vented zee closure "Z16" (perforated) at the top edge of the substrate and parallel to the endwall.
- Fasten the vented endwall "EW17" with #10 pancake head wood screws or roofing nails at 24" o.c.
- Fasten the vented endwall "EW17" to the zee closure "Z16" (perforated) using #12 x 3/4" stitch screws. (Adjacent to the panel ribs).
- Caulk, lap and rivet sequential flashings. (See pg. 49).

Roof Pitch	Dimension @
3:12-6:12	4 1/2"
7:12-9:12	3 3/4"
10:12-12:12	3"

Slope Transition - High Slope to Low Slope

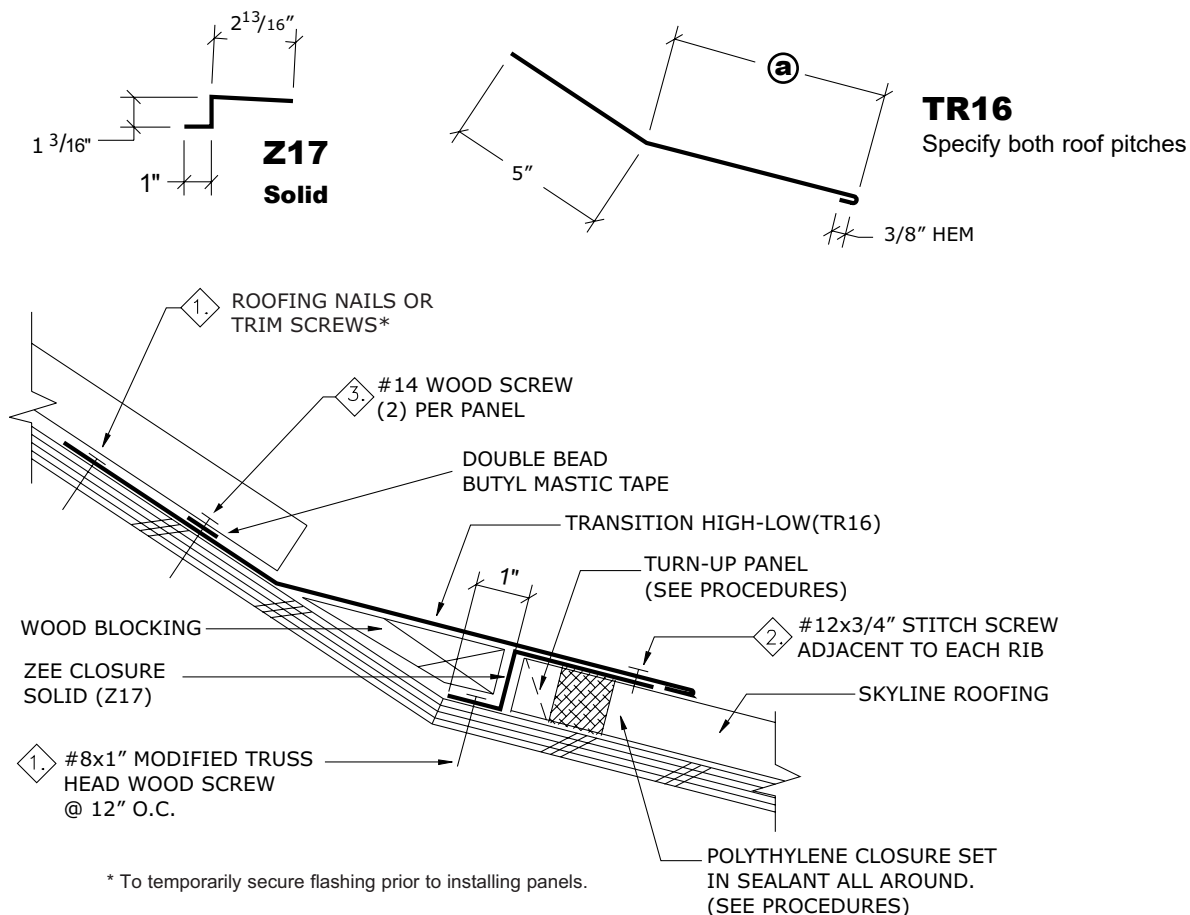

Procedures

- Locate the panels down and parallel to the valley as required. Check the overhang at the eave (See pg. 9).
- Turn up panel. Caulk the bottom and sides of the polyethylene closure, set the closure as shown above and caulk the top.
- Attach the zee closure "Z17" (solid) at the top edge of the substrate and parallel to the valley.
- Provide space between the zee closure "Z17" and the panels to allow for expansion of the panel.
- Install wood blocking as needed for support.
- Fasten the transition flashing "TR16" with #10 pancake head wood screws or roofing nails at 24" o.c.
- Fasten the transition flashing "TR16" to the zee closure using #12 x 3/4" stitch screws. (Adjacent to the panel ribs).
- Caulk, lap and rivet sequential flashings. (See pg. 49).
- Parallel to the transition, place row of double bead butyl mastic tape as shown above.
- Attach the uphill panels as shown.

Roof Pitch Difference	Dimension (a)
2:12	14"
3:12-6:12	8"
7:12-12:12	6"

The roof pitch difference is the difference between the upper and lower slopes. Ex: Upper roof pitch is 7:12 and lower roof pitch is 3:12. Difference is 4:12. Flashing TR16 Dimension 'A' is 8". Inquire with ASC regarding applications where steepest slope exceeds 12:12.

Note: TR17 flashing fit will vary depending on slope combination. Some field adjustment of panel assembly may be required for best fit.

Slope Transition - Low Slope to High Slope

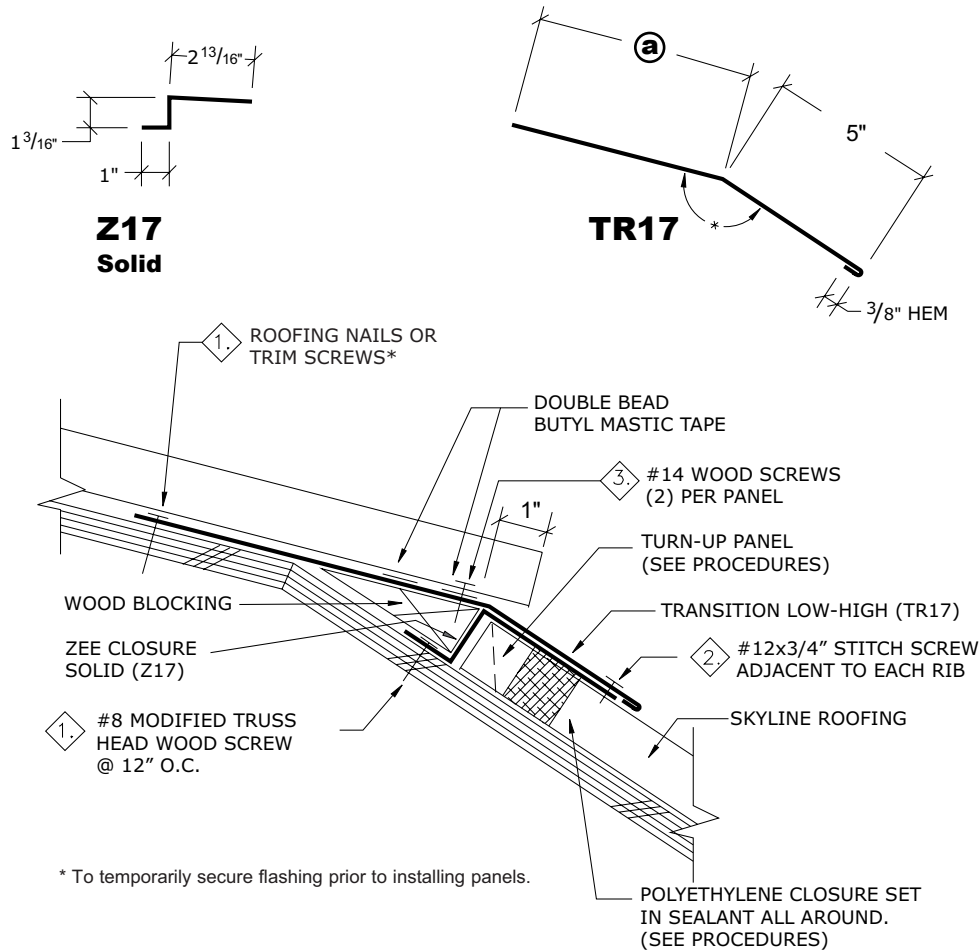

Procedures

- Locate the panels down and parallel to the valley as required. Check the overhang at the eave (See pg. 9).
- Turn up panel. Caulk the bottom and sides of the polyethylene closure, set the closure as shown above and caulk the top.
- Attach the zee closure "Z17" (solid) near the top of the substrate and parallel to the valley.
- Provide space between the zee closure "Z17" and the panels to allow for expansion of the panel.
- Install wood blocking as needed for support.
- Fasten the transition flashing "TR17" with #10 pancake head wood screws or roofing nails at 24" o.c.
- Fasten the transition flashing "TR17" to the zee closure using #12 x 3/4" stitch screws. (Adjacent to the panel ribs).
- Caulk, lap and rivet sequential flashings (See pg. 49).
- Parallel to the transition, place two rows of butyl mastic tape as shown above.
- Attach the uphill panels as shown.

Roof Pitch Difference	Dimension (a)
2:12	14"
3:12-6:12	8"
7:12-12:12	6"

The roof pitch difference is the difference between the upper and lower slopes. Ex: Upper roof pitch is 3:12 and lower roof pitch is 7:12. Difference is 4:12. Flashing TR17 Dimension 'A' is 8". Inquire with ASC regarding applications where steepest slope exceeds 12:12.

Note: TR17 flashing fit will vary depending on slope combination. Some field adjustment of panel assembly may be required for best fit.

Outside Corner Flashing

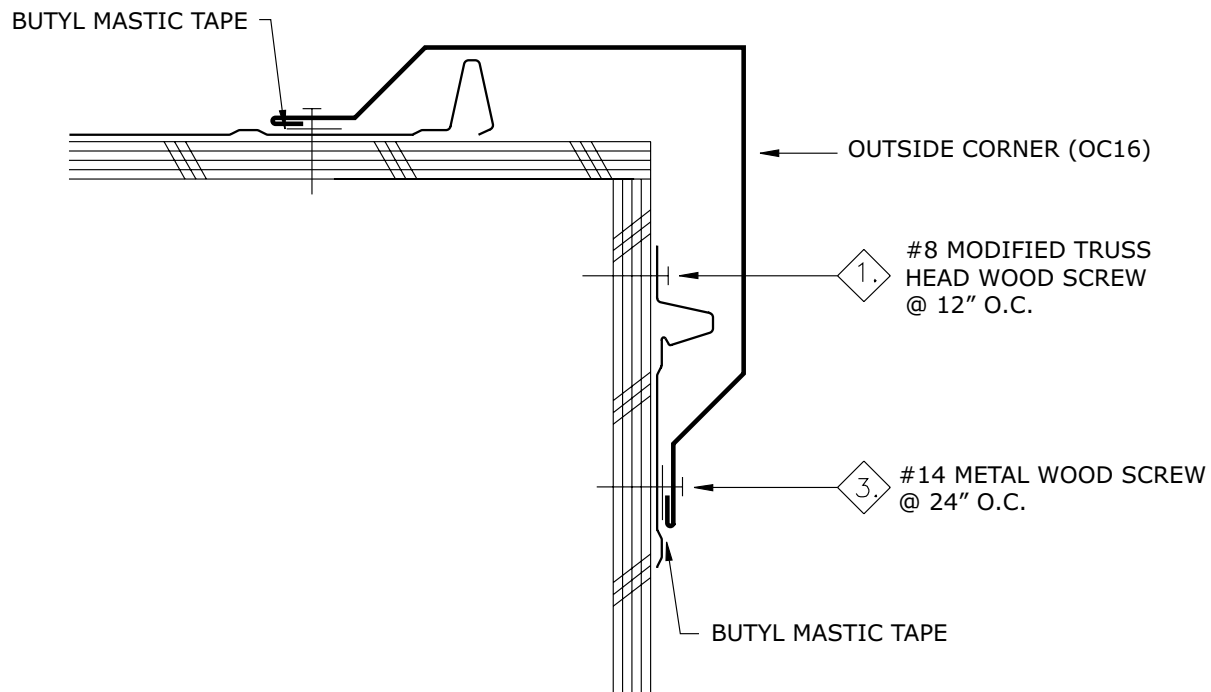
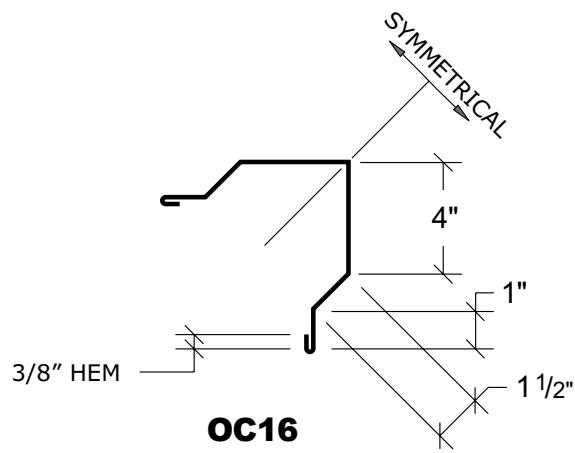

Procedures

- Begin with the bottom-most flashing. Caulk and lap the next flashing a minimum of 3" joining the hem. (See pg. 49).
- Attach the outside corner "OC16" with #14 wood screws at 24" o.c.

Inside Corner Flashing

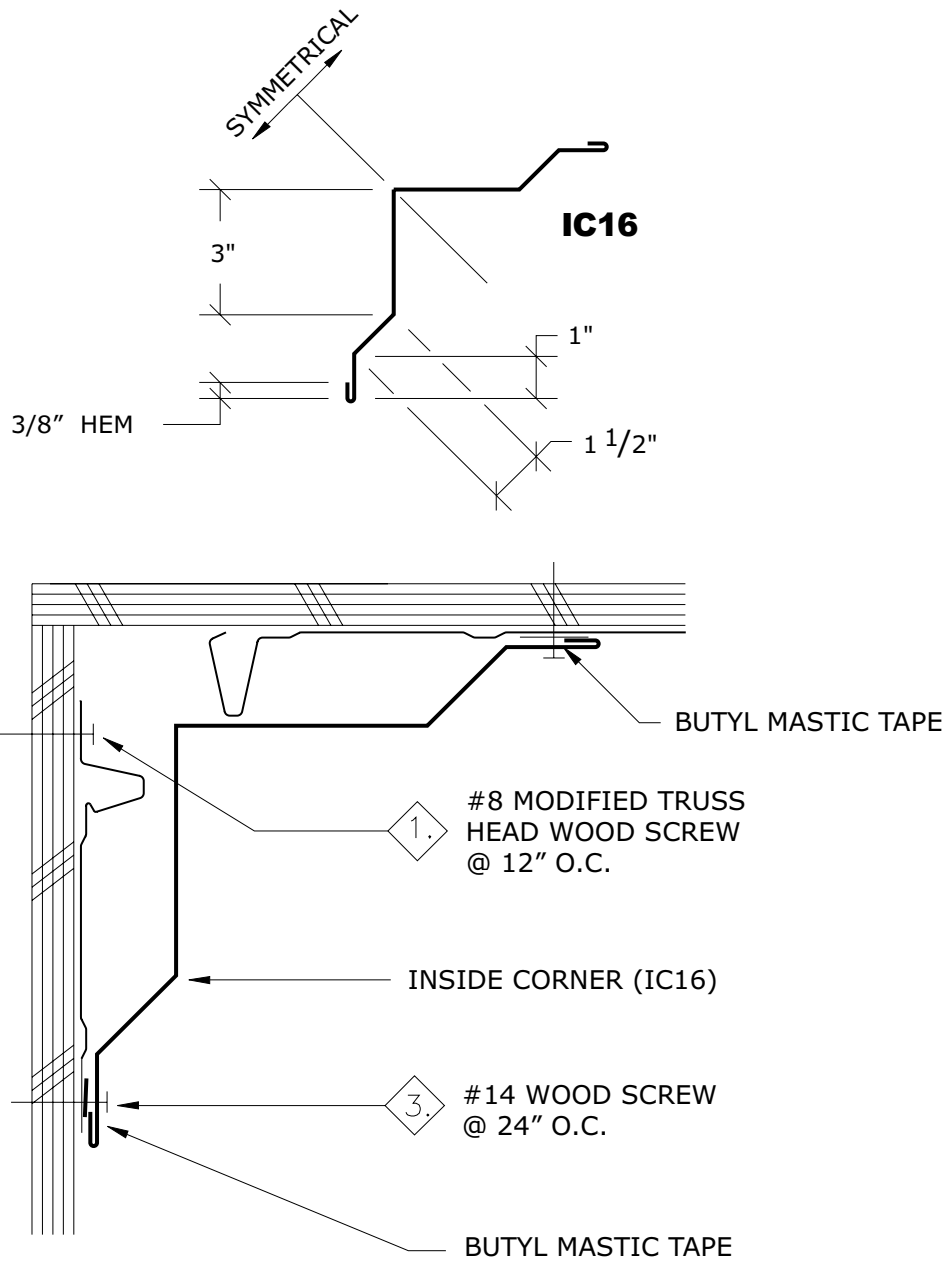

Procedures

- Begin with the bottom most flashing. Caulk and lap the next flashing a minimum of 3" joining the hem. (See pg. 49).
- Attach the outside corner "IC16" with #14 wood screw at 24" o.c.

Base Trim at Drip/Head Flashing

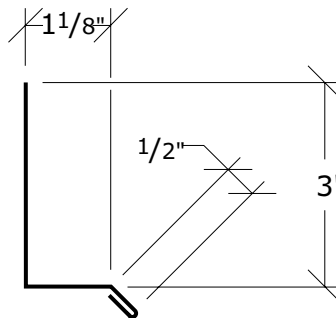

B16

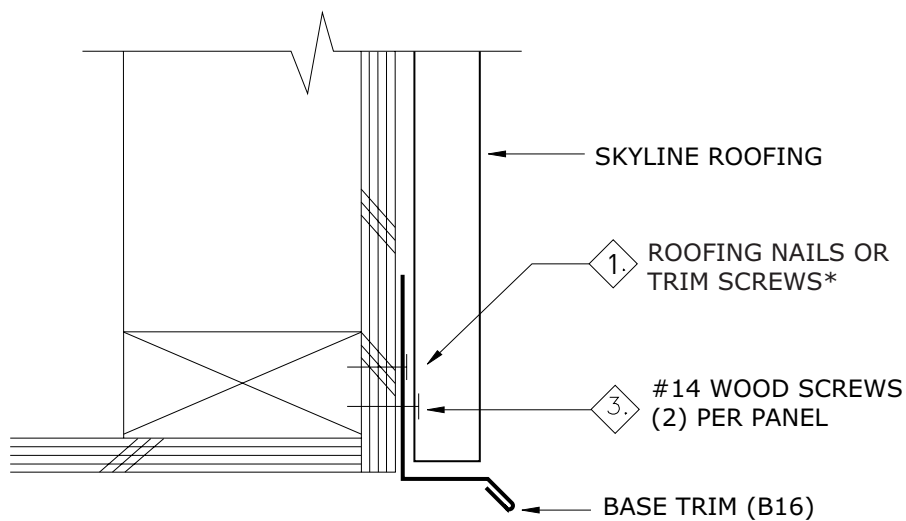

* To temporarily secure flashing prior to installing panels.

Procedures

- Attach the base trim “B16” prior to the installation of the panels.

“C” Trim Flashing/Soffit

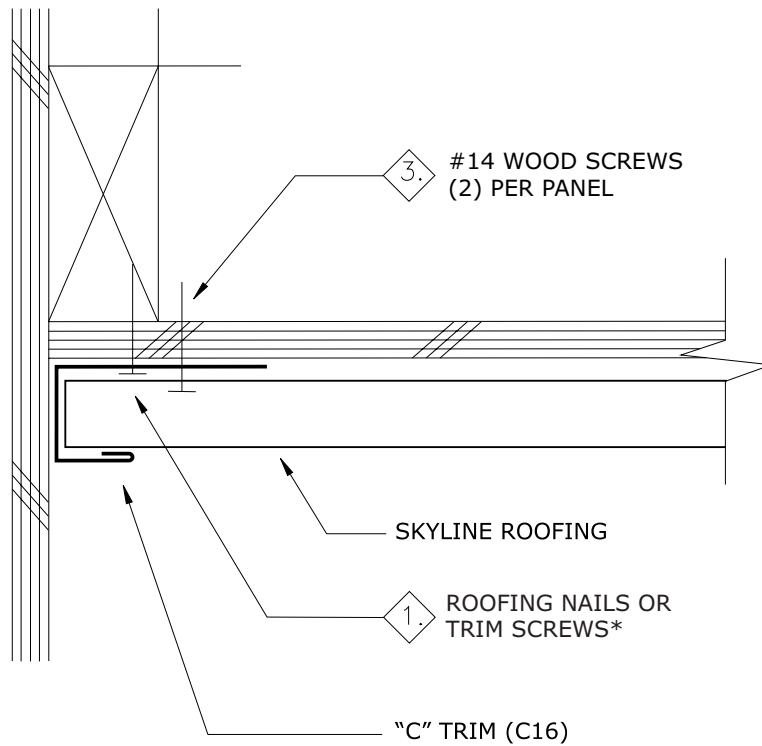
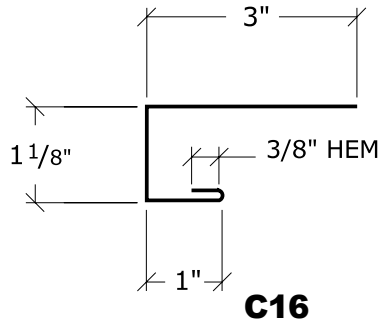

* To temporarily secure flashing prior to installing panels.

Procedures

- Attach the “C” Trim “C16” prior to the installation of the soffit panels.

Chalet Gable Flashing

Note: This flashing must be installed prior to the panels.

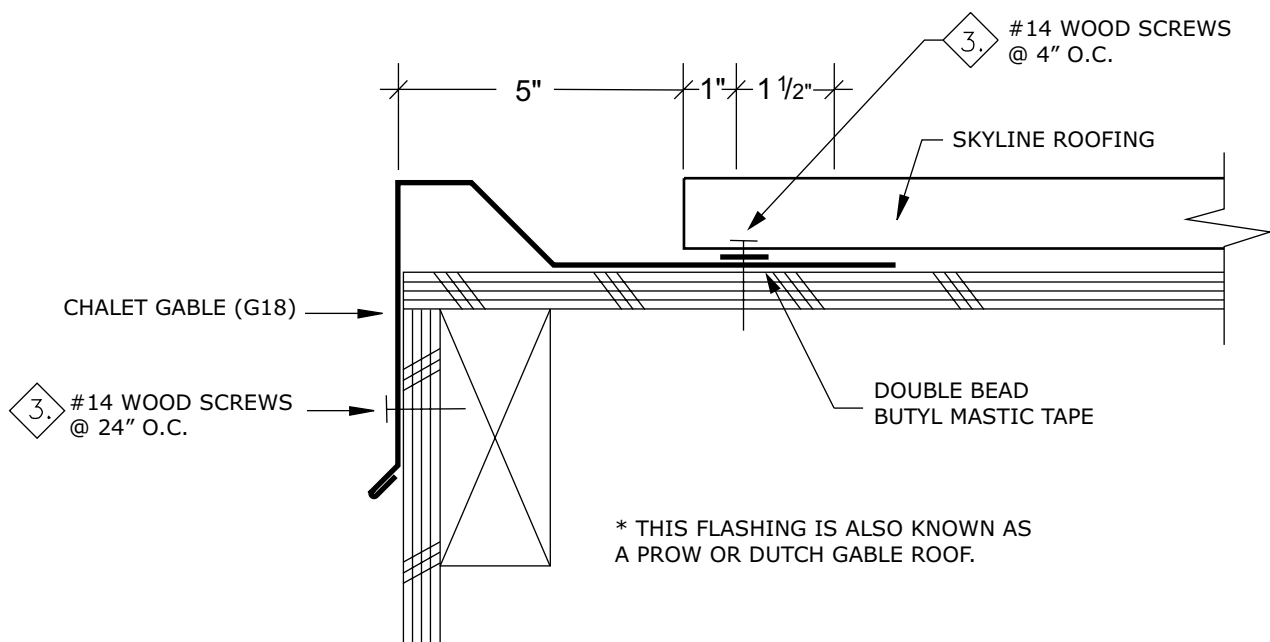
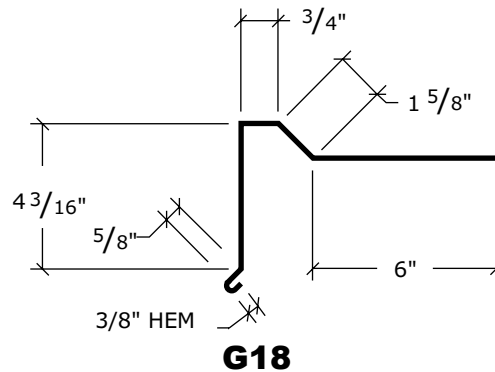

Procedures

- Attach the chalet flashing “G18” using #14 wood screws spaced at 24" o.c.
- Caulk and lap the flashing a minimum of 3" o.c. joining the hem. (See pg. 49).
- Parallel to the face of the flashing, place two rows of butyl mastic tape as shown.
- Field cut the panels holding 5" back from the face of the flashing as shown.
- Attach the panels to the roof and ‘thru-fasten’ along the bottom edge using #14 wood screws spaced at 4" o.c. so they align with the butyl mastic tape.
- Chalet gable to be used with standard eave “E17”. (See pg. 16).

Adjustable Gable Flashing

Note: This flashing must be installed prior to the panels.

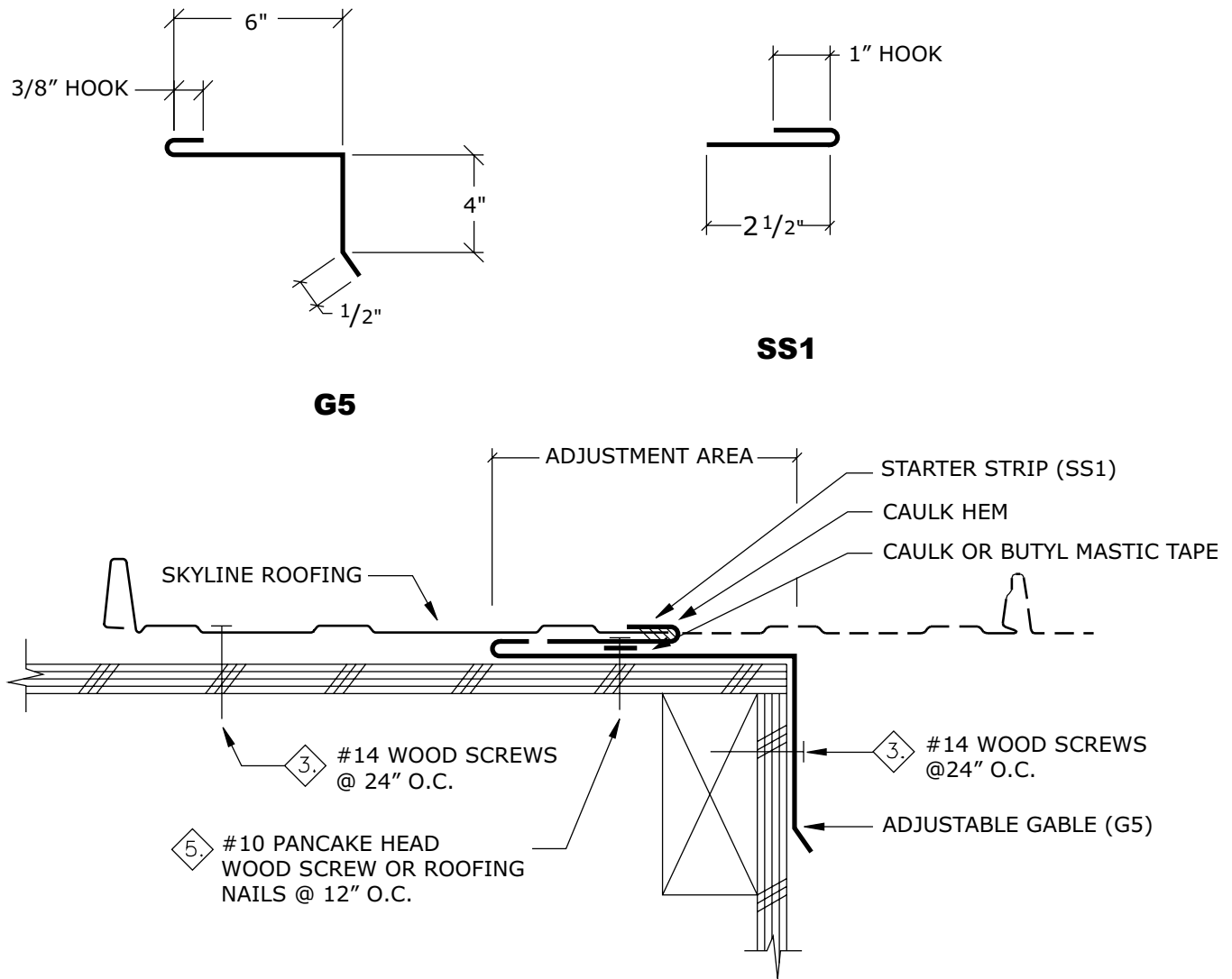

Procedures

- Attach the adjustable gable “G5” using #14 wood screws spaced at 24” o.c.
- Place one row of butyl mastic tape between adjustable gable “G5” and starter strip “SS1”.
- Fasten starter strip “SS1” with #10 pancake head wood screw or roofing nails 12” o.c.
- Caulk and lap the flashing a minimum of 3” o.c. hooking the hem. (See pg. 49).
- Field cut, caulk, and attach the panels and fasten using #14 wood screws at 24” o.c.
- Adjustable gable “G5” is to be used with standard eave “E17”. (See pg. 16).
- See Chalet Gable Flashing, page 37, for additional notes.

Knee Cap Flashing

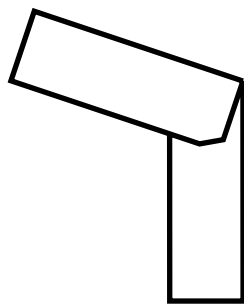

K16

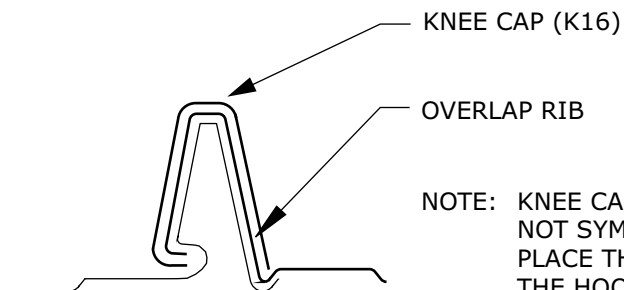

NOTE: KNEE CAP (K16) IS NOT SYMMETRICAL, PLACE THE LEG WITH THE HOOK INTO THE PANEL'S "S" BEND AS SHOWN

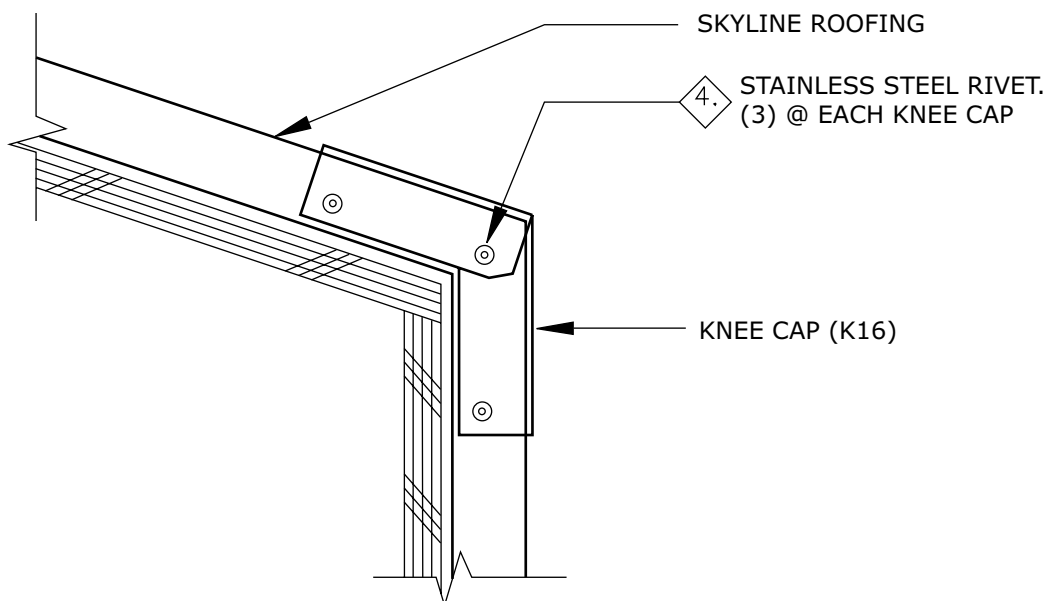

Procedures

- Cut only the major ribs where the panel is to bend.
- Attach the roofing/fascia panels.
- Caulk and cover the gap with the knee cap flashing "K16" and fasten with four (3) rivets.

Note: This detail not recommended in snow climates.

Vent Flashing

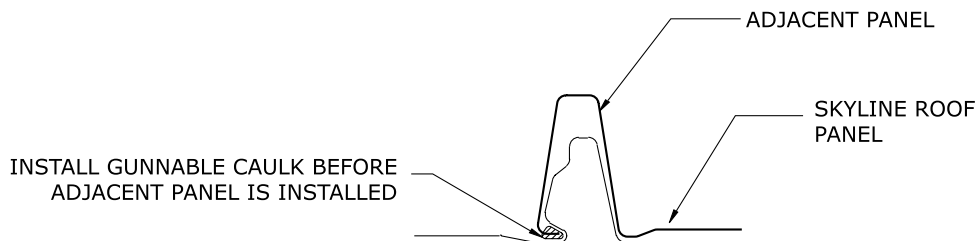
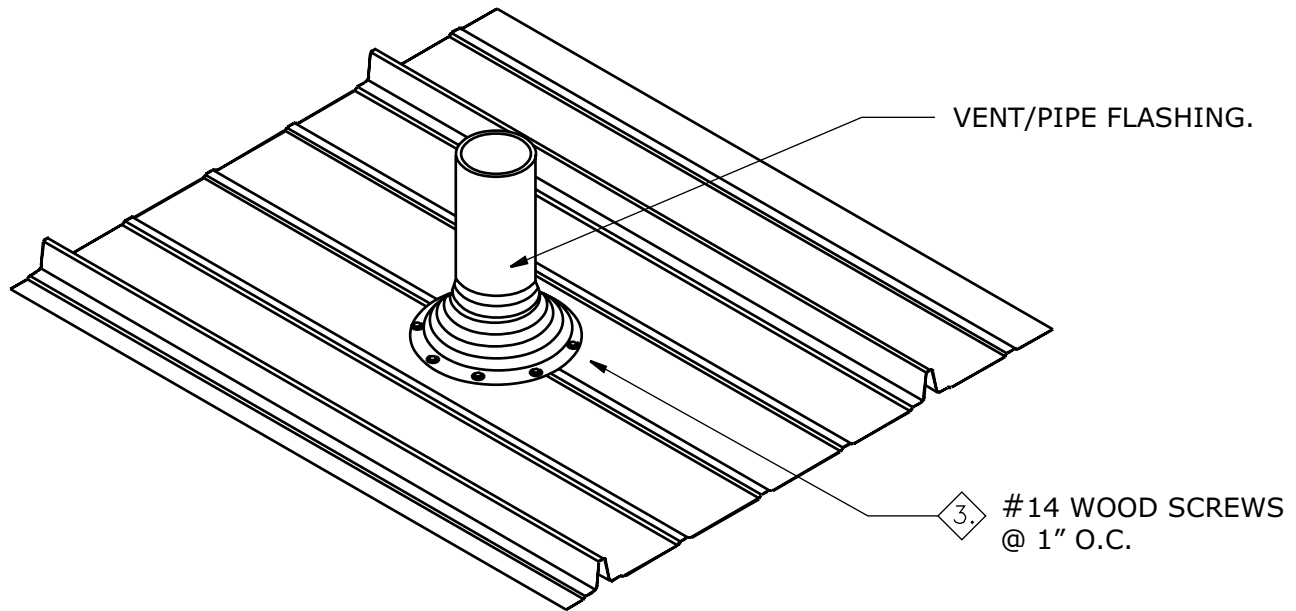

For penetration through the sidelap:

When a penetration occurs through the panel sidelap, install gunnable caulk from the penetration to the ridge, peak or endwall to prevent water from running downhill into the opening.
See detail left.

Procedures

- Trim the opening in the flashing to 20% smaller than the pipe diameter.
- Slide the flashing down over the pipe.
- Seal between the flashing and the roofing with gunnable caulk and set the flashing.
- Form the flashing to fit the profile of the roof.
- Fasten the flashing with #14 x 1" wood screws at 1" o.c.

Note: In many cases it may be easier to locate vent/ pipe flashing in the flat area of the roof panel (as shown) rather than have the penetration occur at a panel rib. Determining panel layout prior to installation often simplifies penetration flashing installation.

Skylight Flashing

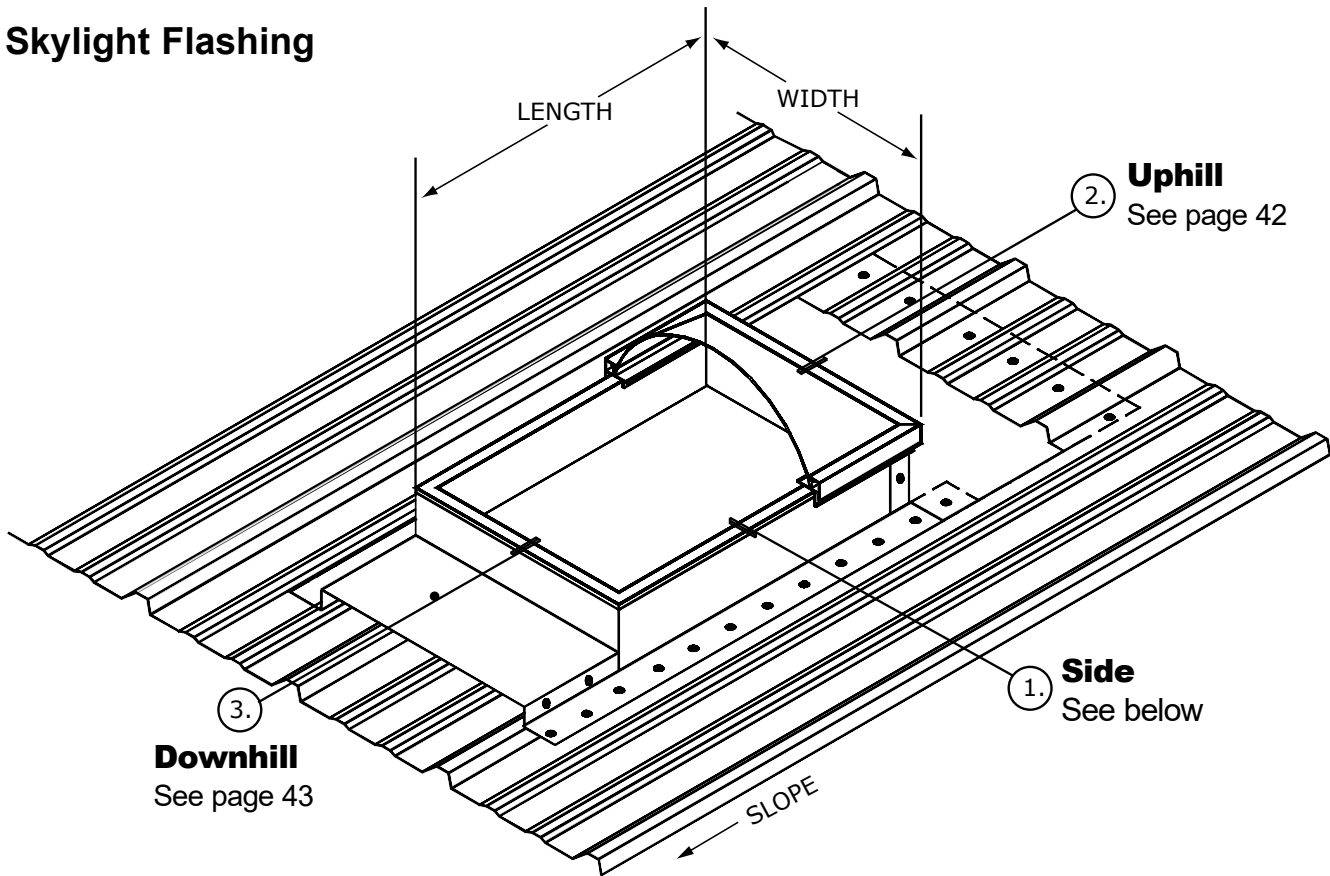

Whenever possible, position the skylight curb so the ribs of the roof panels do not interfere with the flashing.

Cut the Skyline Roofing panels as close to the left, right and downhill sides of the curb as possible. Cut the uphill side 6" up from the curb as indicated on page 42.

Note: Do not fasten down the panels within 24" uphill from the skylight.

1 – Skylight Flashing (Side)

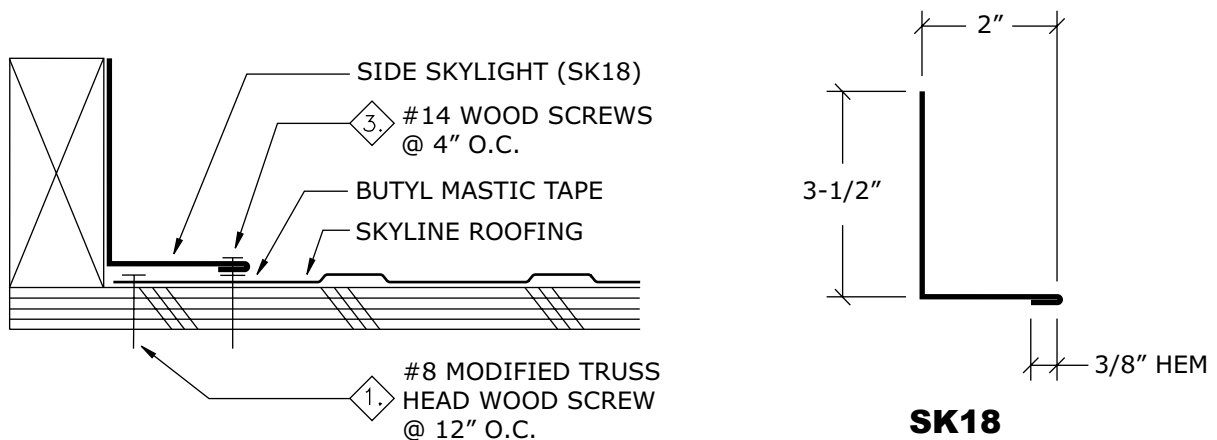

2 – Skylight Flashing (Uphill)

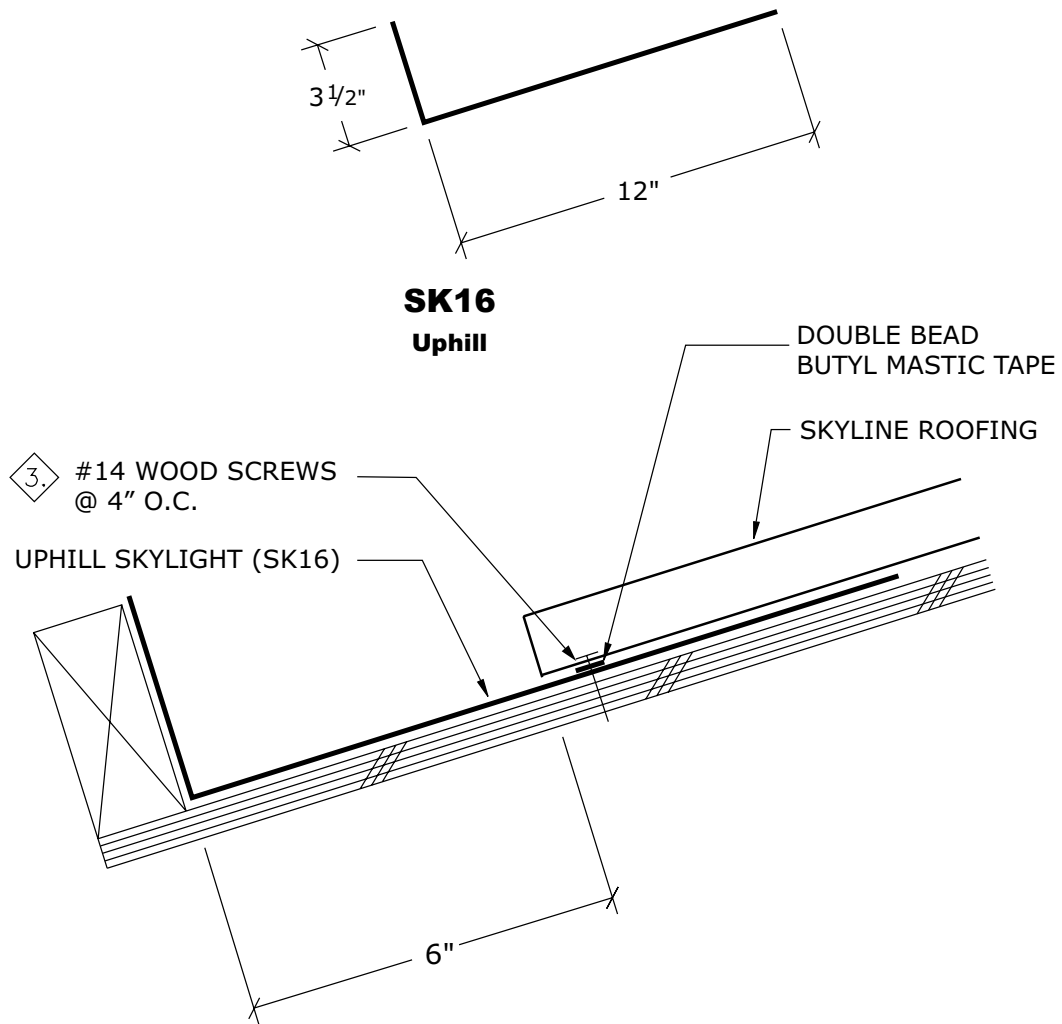

3 – Skylight Flashing (Downhill)

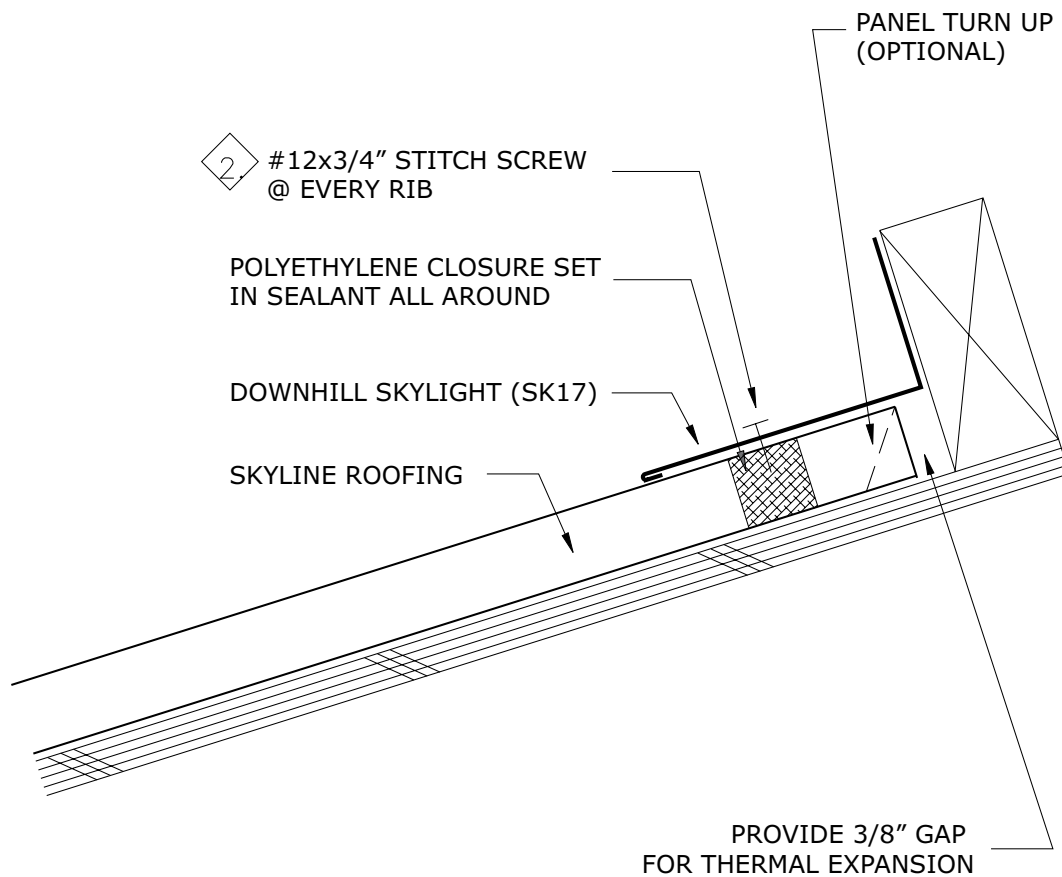
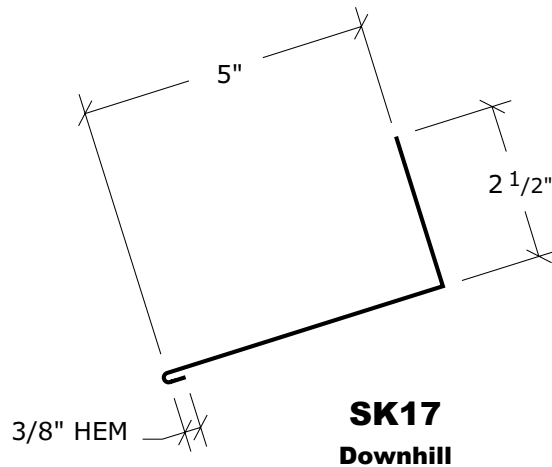

Procedure for the Installation of Skylight Flashings

The skylight flashing will be 4" wider than the width of the curb (2" on each side). Cut a 1/8" slot in the two uphill corners of the Skyline Roofing panel slightly wider than 2 1/16", so the uphill flashing can slide through the two slots. (See illustration #8).

Illustration No. 8

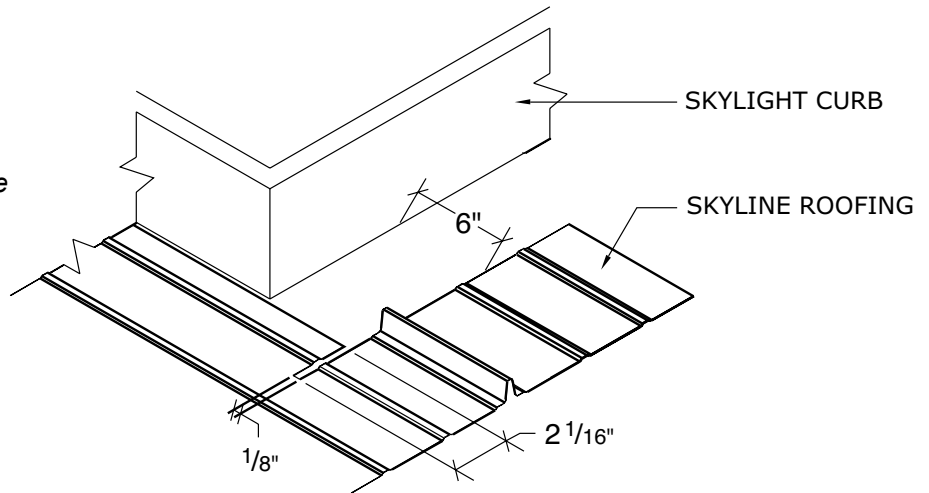

Skylight Flashing Preparation

Right Side

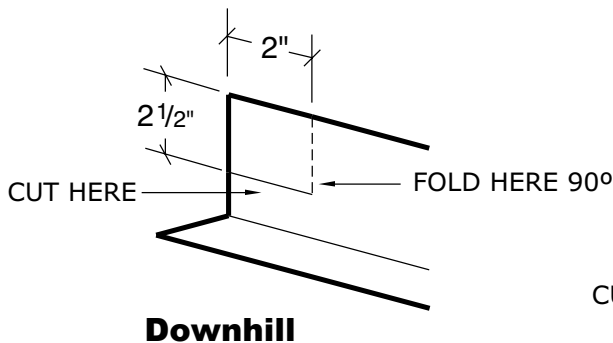
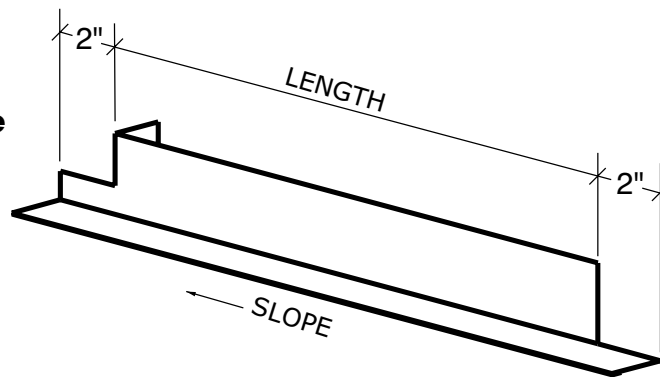

Downhill

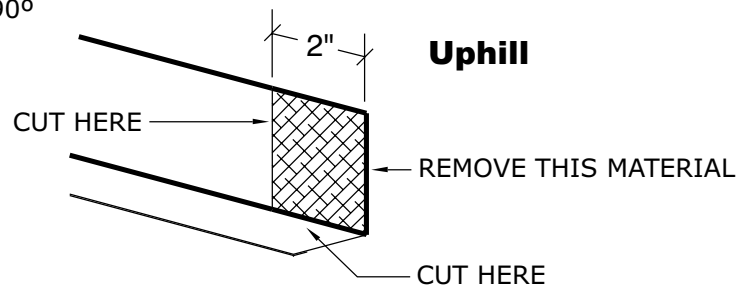

Uphill

Procedures

- Trim and bend the right side skylight flashing as indicated. Trim the left side in a similar fashion.

Note: The left and right side flashings are mirror images of each other.

Skylight Flashing Preparation

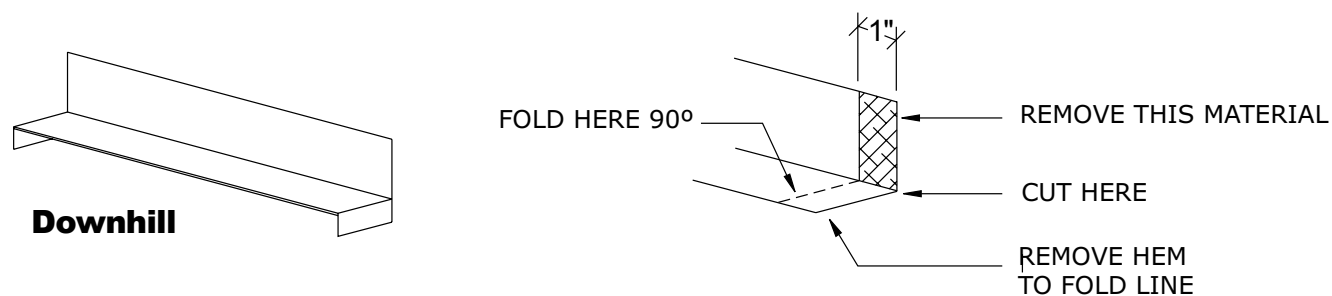
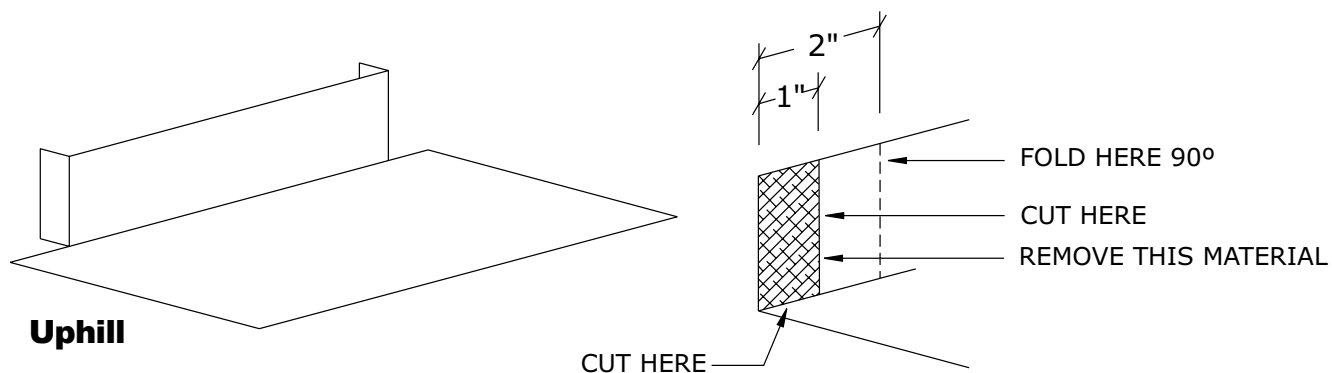

Procedures

- Trim both ends of the uphill and downhill sides of the skylight flashing as indicated.
- Slide the uphill flashing into the slots of the Skyline Roofing and apply liberal amount of gunnable caulking.
- Assemble the skylight as indicated on pages 40-44.
- Trim and assemble chimney flashing similarly.

Chimney Flashing

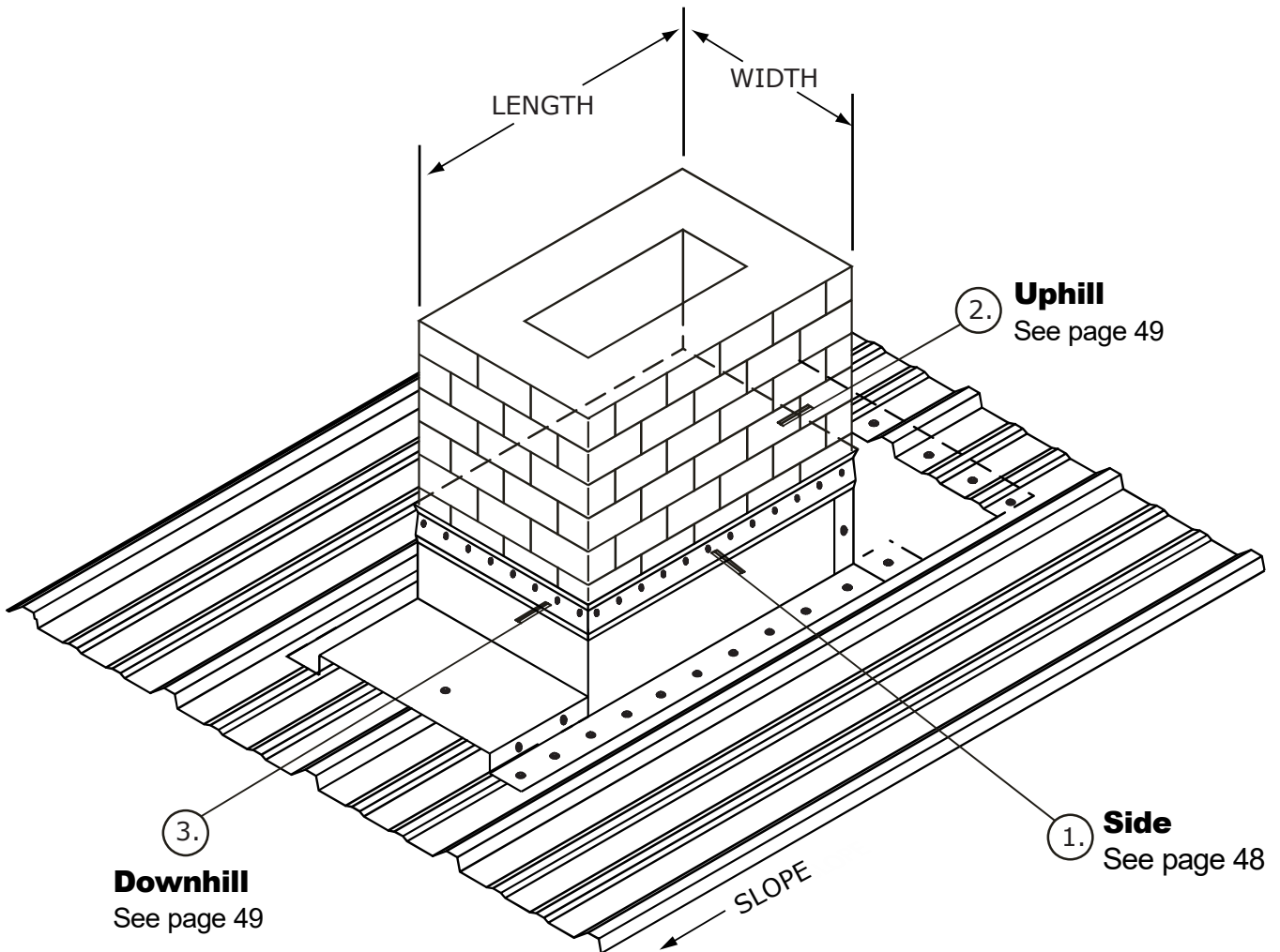

Note: Procedures for the installation of chimney flashings are similar to the skylights. (see pgs. 41-45). The reglet "RG16"*** shown may be deleted if the chimney is clad with siding. (Lap the siding over the flashing and caulk). Be sure to specify the slope and the orientation of the chimney dimensions when ordering this assembly.

** A reglet is a flashing found on the side of a wall, chimney or other similar roof penetration.

(See pgs. 47-48).

1 – Chimney Flashing (Side)

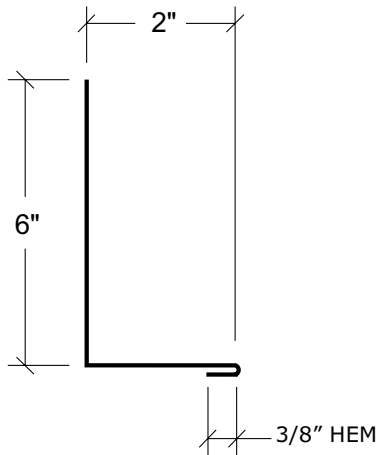

CH18
Side

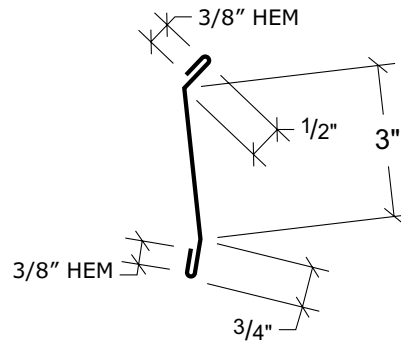

RG16
Reglet

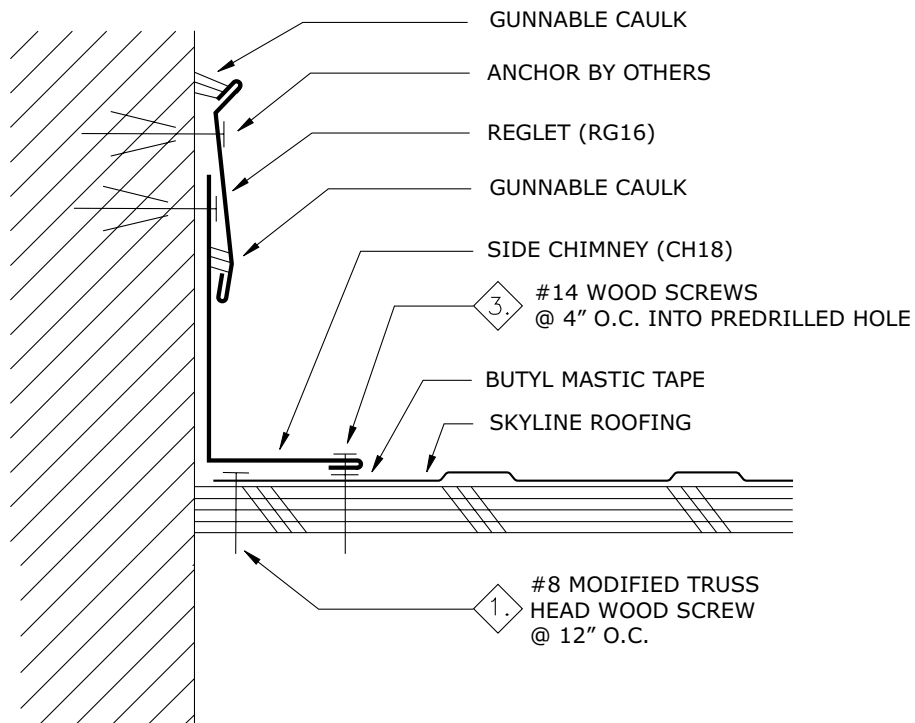

2 – Chimney Flashing (Uphill)

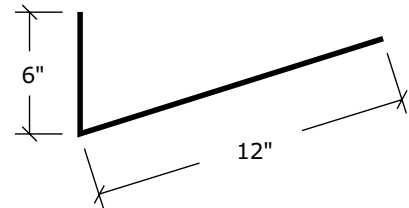
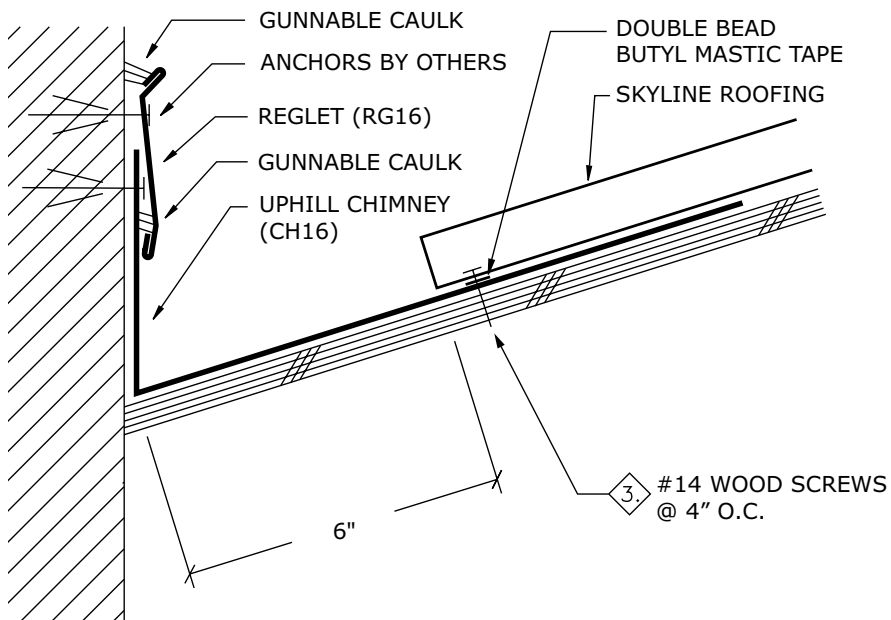

**CH16
 Uphill**

3 – Chimney Flashing (Downhill)

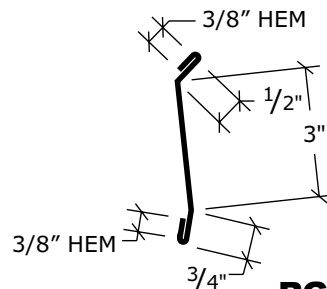
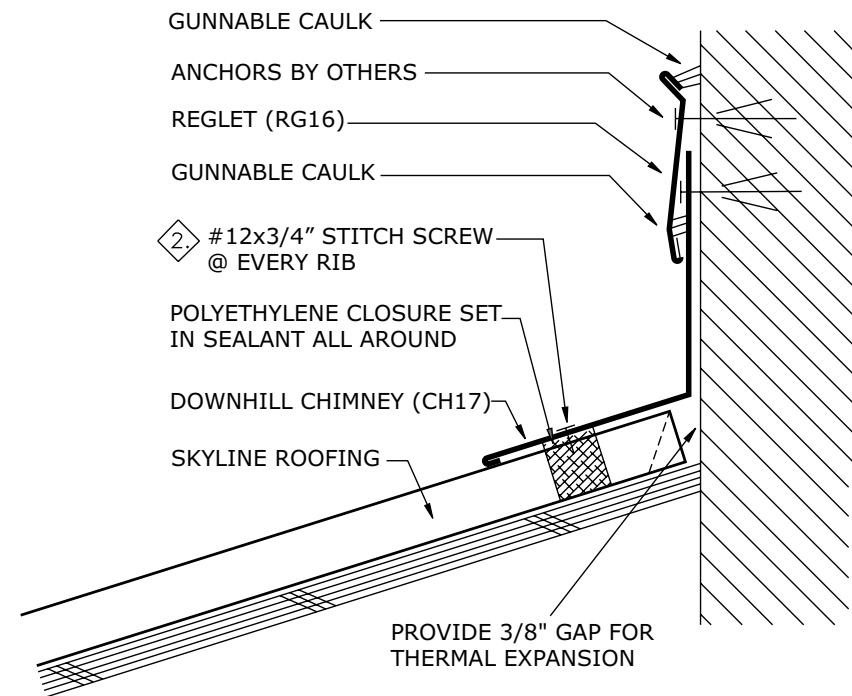

RG16

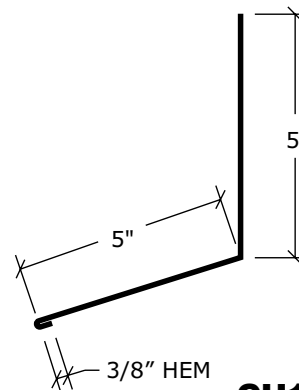

**CH17
 Downhill**

Typical Flashing Lap

Step One

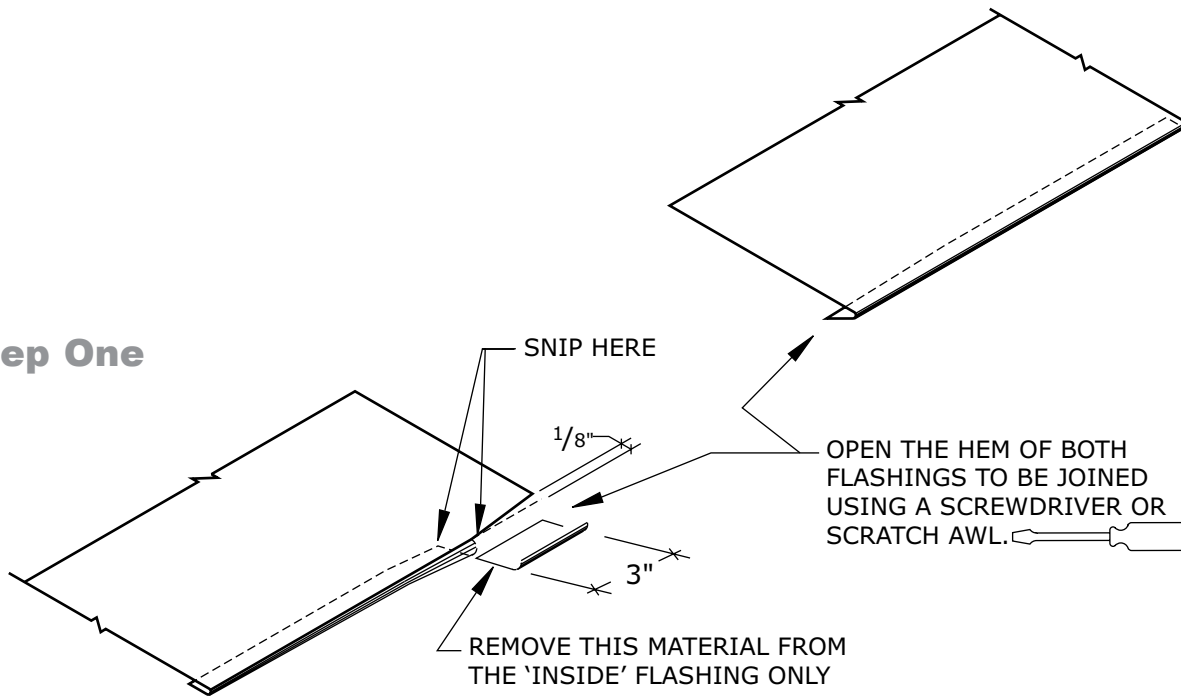

Step Two

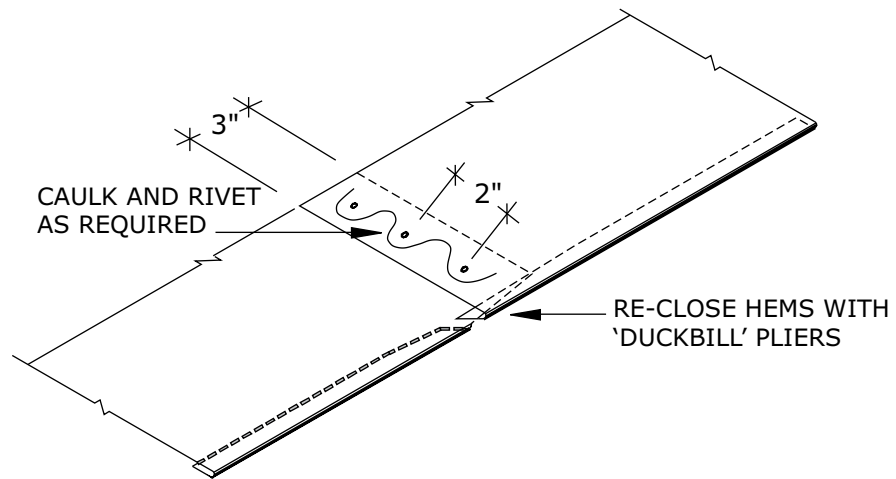

Valley Top End

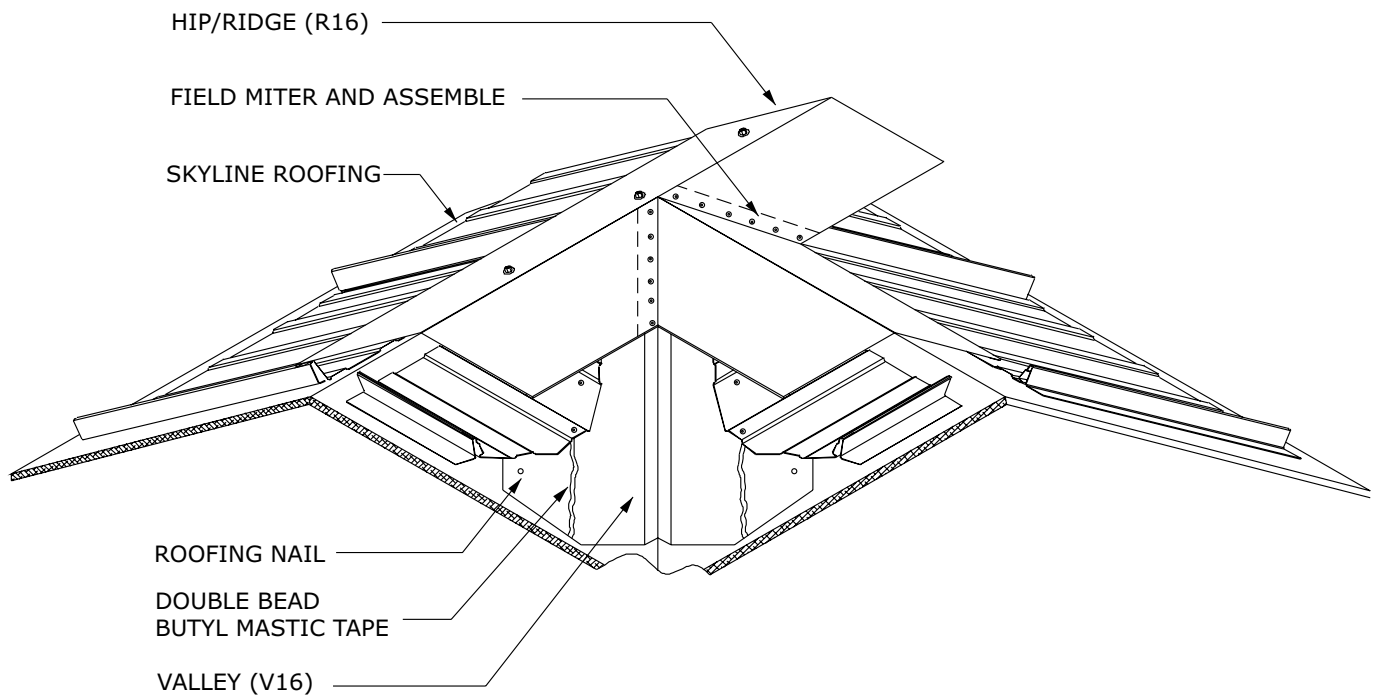

Note: Foam or metal closures and caulking are required between the intersecting ridge cap and the valley flashing to provide adequate weathertightness.

Valley Dormer

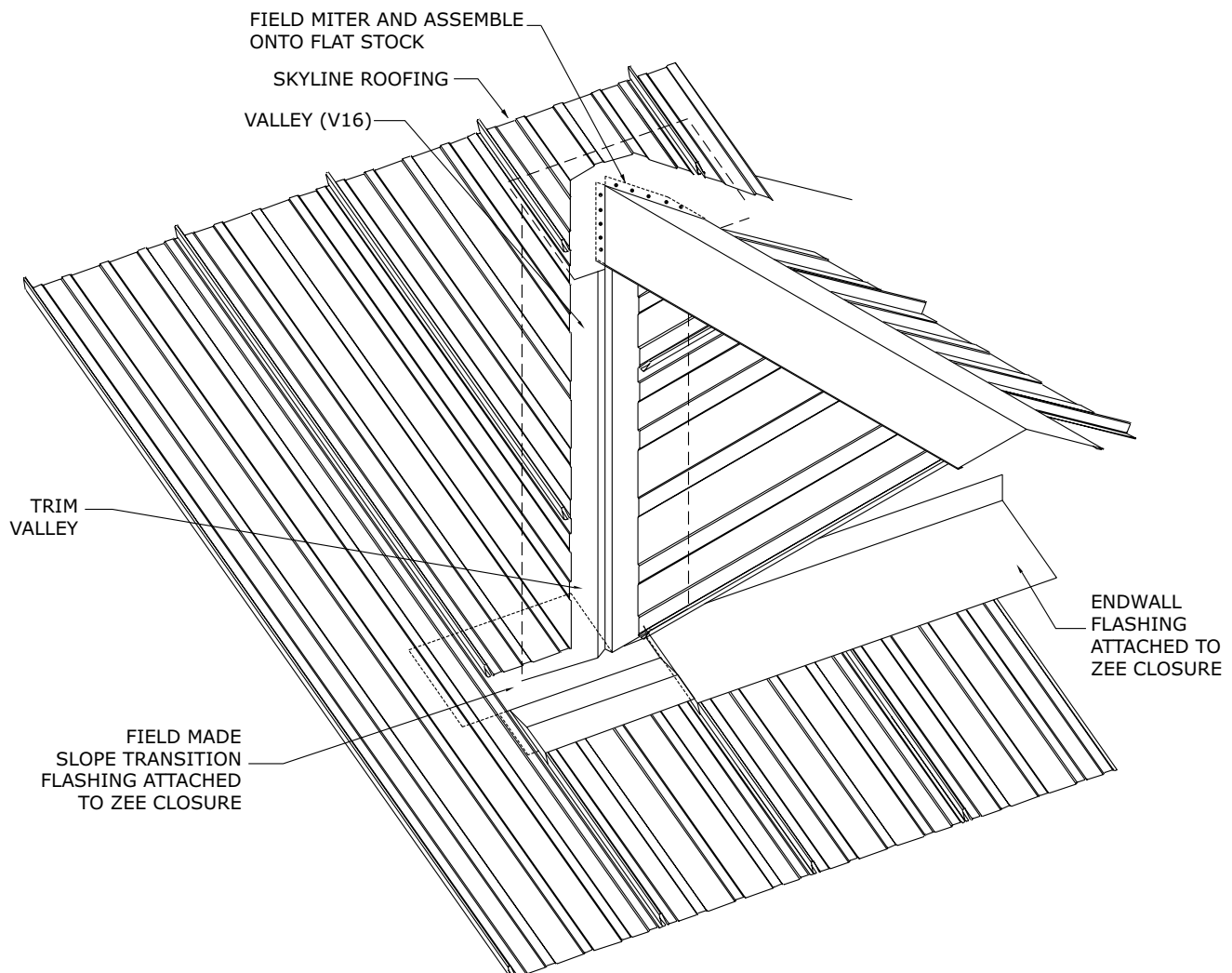

Procedures

- Place a second layer of 36" roof felt in the valley center line with 18" of paper on each side.
- Caulk and lap the subsequent valley flashings a minimum of 8".
- Parallel to the valley, place row of double beaded butyl mastic tape as shown on page 14.
- Field cut the panels holding a minimum of 4" back from the valley as shown. Larger valleys, without the center V, may be required in snow country installations.
- Attach the panels to the roof and 'thru-fasten' along the bottom end using (4) #14 wood screws per panel evenly spaced so they align with the butyl tape sealant as shown on page 14.

Notes:

- Valley dimensions must be the proper width to account for slope, snow, ice and rain conditions. An underlayment such as rubberized cold-applied membrane is recommended. The membrane is installed first, extending 3'-0" up from the center of the valley on each side, with felt overlapping the membrane.
- Foam or metal closures and caulking are required between the intersecting ridge cap and the valley flashing to provide adequate weathertightness.

Manufacturing Facilities:

Anchorage, Alaska

2441 Cinnabar Loop
Anchorage, AK 99507

West Sacramento, California

2110 Enterprise Boulevard
West Sacramento, CA 95691

Salem, Oregon

4063 Salem Industrial Drive NE
Salem, OR 97303
Customer Service Center
800-272-7023 • 503-390-7174

Spokane, Washington

4111 East Ferry Avenue
Spokane, WA 99202
Customer Service Center
800-776-8771 • 509-536-4097

Corporate Headquarters:

ASC Profiles

2110 Enterprise Boulevard
West Sacramento, CA 95691

Visit us at our website:

www.ascbp.com



All information stated in the catalog is correct at time of printing and subject to change without notice, check our website for the latest version.

© 2007-2021 ASC Profiles LLC. All rights reserved. ZINCALUME® is a registered trademark of BlueScope Steel Ltd.

Printed in the USA. 1021 WEB BR108